

Radio Measurement and Test Report

For

Vonino EElectronics LTD.

**Miramar Tower 10F-No.1010, 132 Nathan Road, Tsim Sha Tsui , Kowloon,
Hong Kong**

Test Standard(s): EN 300 328 V1.9.1 (2015-02)

Product Description: Smart Phone

Tested Model: VOLT X

Report No.: STR16128114E-4

Tested Date: 2016-12-12 to 2016-12-21

Issued Date: 2016-12-22

Tested By: Iven Guo / Engineer

Iven Guo

Reviewed By: Silin Chen / EMC Manager

Silin Chen

Approved & Authorized By: Jandy So / PSQ Manager

Jandy So

Prepared By:

Shenzhen SEM.Test Technology Co., Ltd.

1/F, Building A, Hongwei Industrial Park, Liuxian 2nd Road,
Bao'an District, Shenzhen, P.R.C (518101)

Tel.: +86-755-33663308 Fax.: +86-755-33663309 Website: www.semtest.com.cn

Note: This test report is limited to the above client company and the product model only. It may not be duplicated without prior permitted by Shenzhen SEM.Test Technology Co., Ltd.

TABLE OF CONTENTS

1. GENERAL INFORMATION	3
1.1 PRODUCT DESCRIPTION FOR EQUIPMENT UNDER TEST (EUT)	3
1.2 TEST STANDARDS	5
1.3 TEST METHODOLOGY	5
1.4 TEST FACILITY	5
1.5 EUT SETUP AND TEST MODE	6
1.6 MEASUREMENT UNCERTAINTY	6
1.7 TEST EQUIPMENT LIST AND DETAILS	7
2. SUMMARY OF TEST RESULTS	8
3. RF OUTPUT POWER	9
3.1 STANDARD APPLICABLE	9
3.2 TEST PROCEDURE	9
3.3 SUMMARY OF TEST RESULTS	10
4. POWER SPECTRAL DENSITY	16
4.1 STANDARD APPLICABLE	16
4.2 TEST PROCEDURE	16
4.3 SUMMARY OF TEST RESULTS	17
5. ADAPTIVITY AND RECEIVER BLOCKING	22
5.1 STANDARD APPLICATION	22
5.2 TEST PROCEDURE	24
5.3 SUMMARY OF TEST RESULTS/PLOTS	24
6. OCCUPIED CHANNEL BANDWIDTH	35
6.1 STANDARD APPLICATION	35
6.2 TEST PROCEDURE	35
6.3 SUMMARY OF TEST RESULTS/PLOTS	35
7. TRANSMITTER UNWANTED EMISSIONS IN THE OUT-OF-BAND DOMAIN	40
7.1 STANDARD APPLICATION	40
7.2 TEST PROCEDURE	40
7.3 SUMMARY OF TEST RESULTS/PLOTS	42
8. TRANSMITTER UNWANTED EMISSIONS IN THE SPURIOUS DOMAIN	47
8.1 STANDARD APPLICABLE	47
8.2 TEST PROCEDURE	47
8.3 SUMMARY OF TEST RESULTS/PLOTS	47
9. RECEIVER SPURIOUS EMISSIONS	54
9.1 STANDARD APPLICABLE	54
9.2 TEST PROCEDURE	54
9.3 SUMMARY OF TEST RESULTS/PLOTS	54
EXHIBIT 1 - PRODUCT LABELING	58
PROPOSED LABEL LOCATION ON EUT	58
EXHIBIT 2 - EUT PHOTOGRAPHS	59
EXHIBIT 3 - TEST SETUP PHOTOGRAPHS	67

1. GENERAL INFORMATION

1.1 Product Description for Equipment Under Test (EUT)

Client Information

Applicant: Vonino EElectronics LTD.
 Address of applicant: Miramar Tower 10F-No.1010, 132 Nathan Road, Tsim Sha Tsui , Kowloon, Hong Kong

Manufacturer: Gui zhou Fortuneship Technology Co., Ltd.
 Address of manufacturer: No. 4 Plant, High-tech Industrial Park, Xinpu Economic Development Zone) Jingkai Road, Xinpu Jingkai District, Xinpu New District, Zunyi City, Guizhou Province, P. R. China

General Description of EUT	
Product Name:	Smart Phone
Brand Name:	vonino
Model No.:	VOLT X
Adding Model(s):	/
Rated Voltage:	DC 3.8V by Battery
Battery Capacity:	4000mAh
Adapter Model:	JT288-05100 Input: 100-240Vac, 50/60Hz, 0.15A Output: 5.0V \pm %, 1A
Software Version:	Vonino_v1.1.1_20161130
Hardware Version:	F1-4G-V60-CF9-KS670
<i>Note: The test data is gathered from a production sample, provided by the manufacturer.</i>	

E.1 Product Information (Wi-Fi)	
a) Type of modulation:	<input type="checkbox"/> FHSS <input checked="" type="checkbox"/> other forms of modulation
b) Adaptive / non-adaptive:	Adaptive equipment without a non-adaptive mode
c) In case of adaptive equipment:	The equipment has implemented an LBT based DAA mechanism
d) In case of non-adaptive equipment:	No
e) The worst case operational mode for each of the following tests	
RF output power:	802.11b
Power spectrum density:	802.11b
Occupied channel bandwidth:	802.11n-HT40
Transmitter unwanted emissions in the OOB domain:	802.11b
Transmitter unwanted emissions in the spurious domain:	802.11b
Receiver spurious emissions:	802.11b

f) Operating mode(antenna):	Stand-alone Antenna Equipment
g) In case of smart antenna Systems:	No
h) Operating frequency range(s) of the equipment:	2412-2472MHz for 802.11b/g/n(HT20) 2422-2462MHz for 802.11n(HT40)
i) Occupied channel bandwidth(s):	Bandwidth 1(Min): 12.31MHz Bandwidth 2(Max): 36.43MHz
j) Type of equipment:	<input type="checkbox"/> Stand-alone <input checked="" type="checkbox"/> Combined equipment <input type="checkbox"/> Plug-in device
k) The extreme operating conditions	
Extreme voltage range:	DC 3.3V to 4.2V
Extreme temperature range:	-20°C to 55°C
l) The intended combination(s) of the radio equipment power settings and one or more antenna assemblies and their corresponding e.i.r.p levels	
Antenna type:	<input checked="" type="checkbox"/> Integral Antenna <input type="checkbox"/> Dedicated Antennas
Antenna gain:	-0.72dBi
m)Nominal voltage:	Battery DC 3.8V
n) Describe the test modes available which can facilitate testing:	Please refer to Section 1.5
o) The equipment type	Wi-Fi
E.2 Power Level Setting	
Highest EIRP value:	13.97dBm
Conducted power:	14.69dBm
Listed as power setting:	Default
E.3 Additional Information	
Modulation:	CCK, OFDM, QPSK, BPSK, 16QAM, 64QAM
Unmodulated modes:	No
Duty cycle:	Continuous operation possible for testing purposes
Type of the UUT:	Production models
Supporting equipment provided:	Please refer to Section 1.5

1.2 Test Standards

The following report is prepared on behalf of the Vonino EElectronics LTD. in accordance with ETSI EN 300328, Electromagnetic compatibility and Radio spectrum Matters (ERM); Wideband transmission systems; Data transmission equipment operating in the 2,4 GHz ISM band and using wide band modulation techniques; Harmonized EN covering essential requirements under article 3.2 of the R&TTE Directive.

The objective of the manufacturer is to demonstrate compliance with ETSI EN 300328.

Maintenance of compliance is the responsibility of the manufacturer. Any modification of the product maybe which result in lowering the emission/immunity should be checked to ensure compliance has been maintained

1.3 Test Methodology

All measurements contained in this report were conducted with ETSI EN 300328, Electromagnetic compatibility and Radio spectrum Matters (ERM); Wideband transmission systems; Data transmission equipment operating in the 2,4 GHz ISM band and using wide band modulation techniques; Harmonized EN covering essential requirements under article 3.2 of the R&TTE Directive.

1.4 Test Facility

FCC – Registration No.: 934118

Shenzhen SEM.Test Technology Co., Ltd. EMC Laboratory has been registered and fully described in a report filed with the (FCC) Federal Communications Commission. The acceptance letter from the FCC is maintained in our files and the Registration is 934118.

Industry Canada (IC) Registration No.: 11464A

The 3m Semi-anechoic chamber of Shenzhen SEM.Test Technology Co., Ltd. has been registered by Certification and Engineering Bureau of Industry Canada for radio equipment testing with Registration No.: 11464A.

CNAS Registration No.: L4062

Shenzhen SEM.Test Technology Co., Ltd. is a testing organization accredited by China National Accreditation Service for Conformity Assessment (CNAS) according to ISO/IEC 17025. The accreditation certificate number is L4062. All measurement facilities used to collect the measurement data are located at 1/F, Building A, Hongwei Industrial Park, Liuxian 2nd Road, Bao'an District, Shenzhen, P.R.C (518101).

1.5 EUT Setup and Test Mode

The equipment under test (EUT) was configured to measure its highest possible emission/immunity level. The test modes were adapted according to the operation manual for use, the EUT was operated in the engineering mode to fix the Tx frequency that was for the purpose of the measurements, more detailed description as follows:

Test Mode List		
Test Mode	Description	Remark
TM1	802.11b	2412MHz, 2442MHz, 2472MHz
TM2	802.11g	2412MHz, 2442MHz, 2472MHz
TM3	802.11n-HT20	2412MHz, 2442MHz, 2472MHz
TM4	802.11n-HT40	2422MHz, 2442MHz, 2462MHz
TM5	Receiving	/

Note: The product is a Load Based Equipment, The value of q is selected by the manufacturer is 32

Test Conditions					
	Normal	LTLV	LTHV	HTHV	HTLV
Temperature (°C)	20	-20	-20	55	55
Voltage (V)	3.8	4.2	3.3	4.2	3.3

Accessories Equipment List and Details			
Description	Manufacturer	Model No.	Serial Number
Notebook	Lenovo	T410	/

Accessories Cable List and Details			
Cable Description	Length (m)	Shielded/Unshielded	With Core/Without Core
/	/	/	/

EUT Cable List and Details			
Cable Description	Length (m)	Shielded/Unshielded	With Core/Without Core
USB Cable	1.0	Shielded	Without Ferrite
Earplug Cable	1.2	Unshielded	Without Ferrite

1.6 Measurement Uncertainty

Measurement uncertainty		
Parameter	Conditions	Uncertainty
RF Output Power	Conducted	$\pm 0.42\text{dB}$
Occupied Bandwidth	---	$\pm 1 \times 10^{-7}$
Power Spectral Density	Conducted	$\pm 0.70\text{dB}$
Transmitter Spurious Emissions	Radiated	$\pm 5.2\text{dB}$
Receiver Spurious Emissions	Radiated	$\pm 5.2\text{dB}$

1.7 Test Equipment List and Details

Description	Manufacturer	Model	Serial Number	Cal Date	Due Date
Spectrum Analyzer	Agilent	N9020A	US47140102	2016-06-04	2017-06-03
Signal Generator	Agilent	83752A	3610A01453	2016-06-04	2017-06-03
Vector Signal Generator	Agilent	N5182A	MY47070202	2016-06-04	2017-06-03
Power Sensor	Agilent	U2021XA	MY54250019	2016-06-04	2017-06-03
Power Sensor	Agilent	U2021XA	MY54250021	2016-06-04	2017-06-03
Power Sensor	Agilent	U2021XA	MY54210040	2016-06-04	2017-06-03
Power Sensor	Agilent	U2021XA	MY54260021	2016-06-04	2017-06-03
Simultaneous Sampling	Agilent	U2531A	TW54243509	2016-06-04	2017-06-03
Power Splitter	Mini-Circuits	Z4PD-642W-S+	N846501416	2016-06-04	2017-06-03
Spectrum Analyzer	R&S	FSP	836079/035	2016-06-04	2017-06-03
Pre-amplifier	Agilent	8447F	3113A06717	2016-06-04	2017-06-03
Pre-amplifier	Compliance Direction	PAP-0118	24002	2016-06-04	2017-06-03
Trilog Broadband Antenna	SCHWARZBECK	VULB9163	9163-333	2016-06-04	2017-06-03
Horn Antenna	ETS	3117	00086197	2016-06-04	2017-06-03
Spectrum Analyzer	Agilent	E4407B	MY41440400	2016-06-04	2017-06-03

2. SUMMARY OF TEST RESULTS

Standards	Reference	Description of Test Item	Result
EN 300328 V1.9.1 (2015-02)	4.3.2.2	RF Output Power	Passed
	4.3.2.3	Power Spectral Density	Passed
	4.3.2.4	Duty Cycle, Tx-sequence, Tx-gap	N/A
	4.3.2.5	Medium Utilisation (MU) Factor	N/A
	4.3.2.6	Adaptivity (Adaptive Frequency Hopping)	Passed
	4.3.2.7	Occupied Channel Bandwidth	Passed
	4.3.2.8	Transmitter Unwanted Emissions in the Out-of-band Domain	Passed
	4.3.2.9	Transmitter Unwanted Emissions in the Spurious Domain	Passed
	4.3.2.10	Receiver Spurious Emissions	Passed
	4.3.2.11	Receiver Blocking	Passed
Passed: The EUT complies with the essential requirements in the standard Failed: The EUT does not comply with the essential requirements in the standard N/A: not applicable			

3. RF Output Power

3.1 Standard Applicable

According to Section 4.3.1.2.3, The maximum RF output power for adaptive Frequency Hopping equipment shall be equal to or less than 20 dBm. The maximum RF output power for non-adaptive Frequency Hopping equipment, shall be declared by the supplier. The maximum RF output power for this equipment shall be equal to or less than the value declared by the supplier. This declared value shall be equal to or less than 20 dBm.

According to Section 4.3.2.2.3, For adaptive equipment using wide band modulations other than FHSS, the maximum RF output power shall be 20 dBm. The maximum RF output power for non-adaptive equipment shall be declared by the supplier and shall not exceed 20 dBm. For non-adaptive equipment using wide band modulations other than FHSS, the maximum RF output power shall be equal to or less than the value declared by the supplier.

3.2 Test Procedure

According to section 5.3.2.2.1.2 of the standard EN 300328, the test procedure shall be as follows:

Step 1:

- Use a fast power sensor suitable for 2,4 GHz and capable of 1 MS/s.
- Use the following settings: - Sample speed 1 MS/s or faster.
- The samples must represent the power of the signal.
- Measurement duration: For non-adaptive equipment: equal to the observation period defined in clauses 4.3.1.2.1 or 4.3.2.3.1. For adaptive equipment, the measurement duration shall be long enough to ensure a minimum number of bursts (at least 10) are captured.

NOTE 1: For adaptive equipment, to increase the measurement accuracy, a higher number of bursts may be used.

Step 2:

- For conducted measurements on devices with one transmit chain:
 - Connect the power sensor to the transmit port, sample the transmit signal and store the raw data. Use these stored samples in all following steps.
- For conducted measurements on devices with multiple transmit chains:
 - Connect one power sensor to each transmit port for a synchronous measurement on all transmit ports.
 - Trigger the power sensors so that they start sampling at the same time. Make sure the time difference between the samples of all sensors is less than half the time between two samples.
 - For each individual sampling point (time domain), sum the coincident power samples of all ports and store them. Use these summed samples in all following steps..

Step 3:

- Find the start and stop times of each burst in the stored measurement samples.

The start and stop times are defined as the points where the power is at least 30 dB below the highest value of the stored samples in step 2.

NOTE 2: In case of insufficient dynamic range, the value of 30 dB may need to be reduced appropriately.

Step 4:

• Between the start and stop times of each individual burst calculate the RMS power over the burst using the formula below. Save these Pburst values, as well as the start and stop times for each burst.

$$P_{burst} = \frac{1}{k} \sum_{n=1}^k P_{sample}(n)$$

with 'k' being the total number of samples and 'n' the actual sample number

Step 5:

• The highest of all Pburst values (value "A" in dBm) will be used for maximum e.i.r.p. calculations.

Step 6:

- Add the (stated) antenna assembly gain "G" in dBi of the individual antenna.
- If applicable, add the additional beamforming gain "Y" in dB.
- If more than one antenna assembly is intended for this power setting, the maximum overall antenna gain (G or G + Y) shall be used.
- The RF Output Power (P) shall be calculated using the formula below: $P = A + G + Y$
- This value, which shall comply with the limit given in clause 4.3.1.2.3 or clause 4.3.2.2.3, shall be recorded in the test report.

3.3 Summary of Test Results

Test Conditions	EIRP (dBm)			Limit
	Lowest CH	Middle CH	Highest CH	dBm
802.11b				
Normal	13.97	13.48	12.33	20
LTLV	13.91	13.43	12.30	20
LTHV	13.95	13.41	12.32	20
HTHV	13.90	13.45	12.31	20
HTLV	13.93	13.47	12.33	20
802.11g				
Normal	11.31	11.04	9.78	20
LTLV	11.28	11.01	9.75	20
LTHV	11.31	11.03	9.71	20
HTHV	11.30	11.00	9.73	20
HTLV	11.25	11.04	9.78	20
802.11n HT20				
Normal	11.05	11.20	9.42	20
LTLV	11.00	11.19	9.40	20
LTHV	11.03	11.15	9.35	20
HTHV	11.01	11.20	9.33	20
HTLV	11.05	11.13	9.39	20
802.11n HT40				
Normal	10.21	10.21	9.34	20
LTLV	10.20	10.13	9.33	20
LTHV	10.18	10.18	9.31	20
HTHV	10.13	10.16	9.33	20
HTLV	10.17	10.21	9.32	20

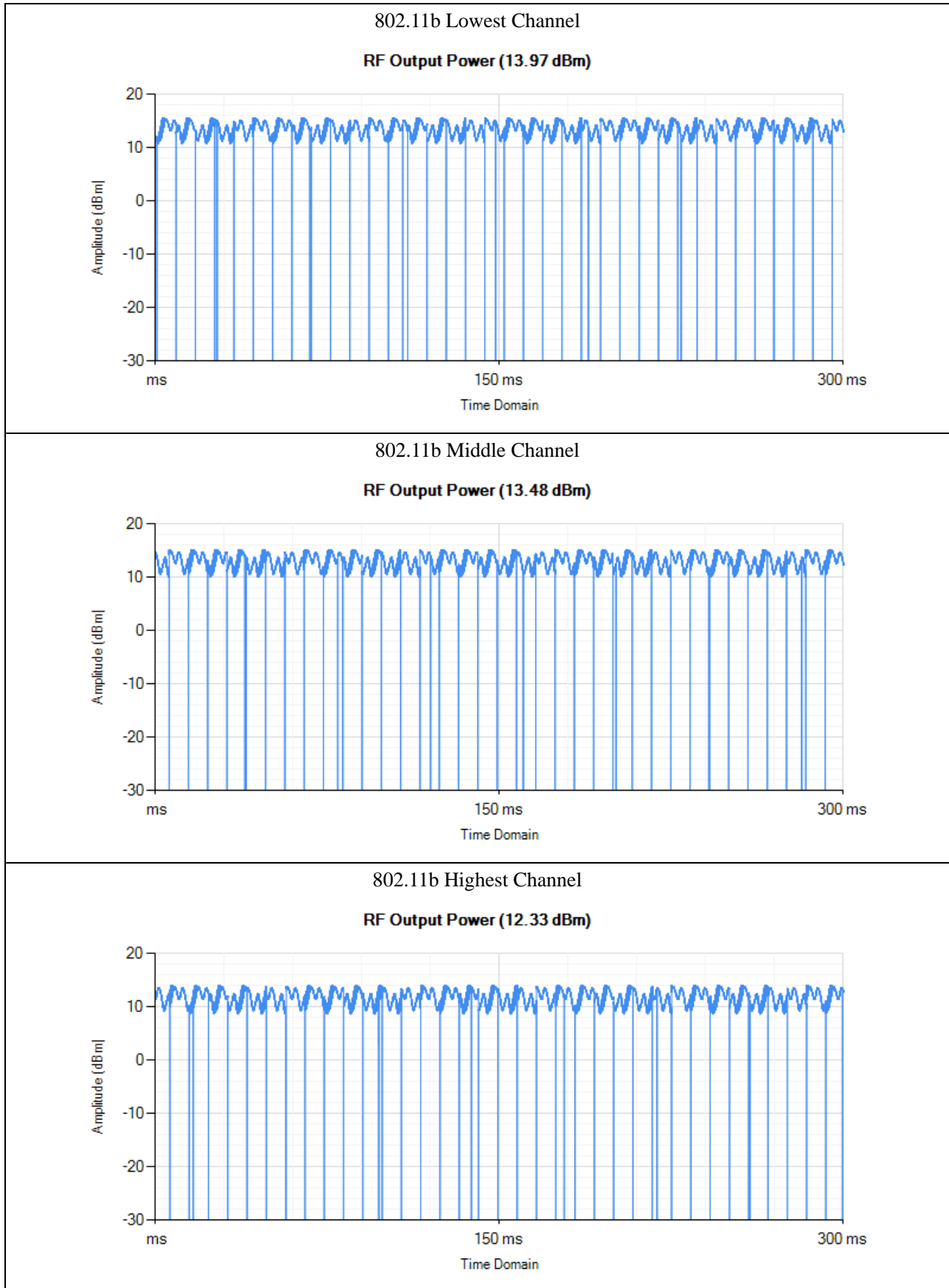

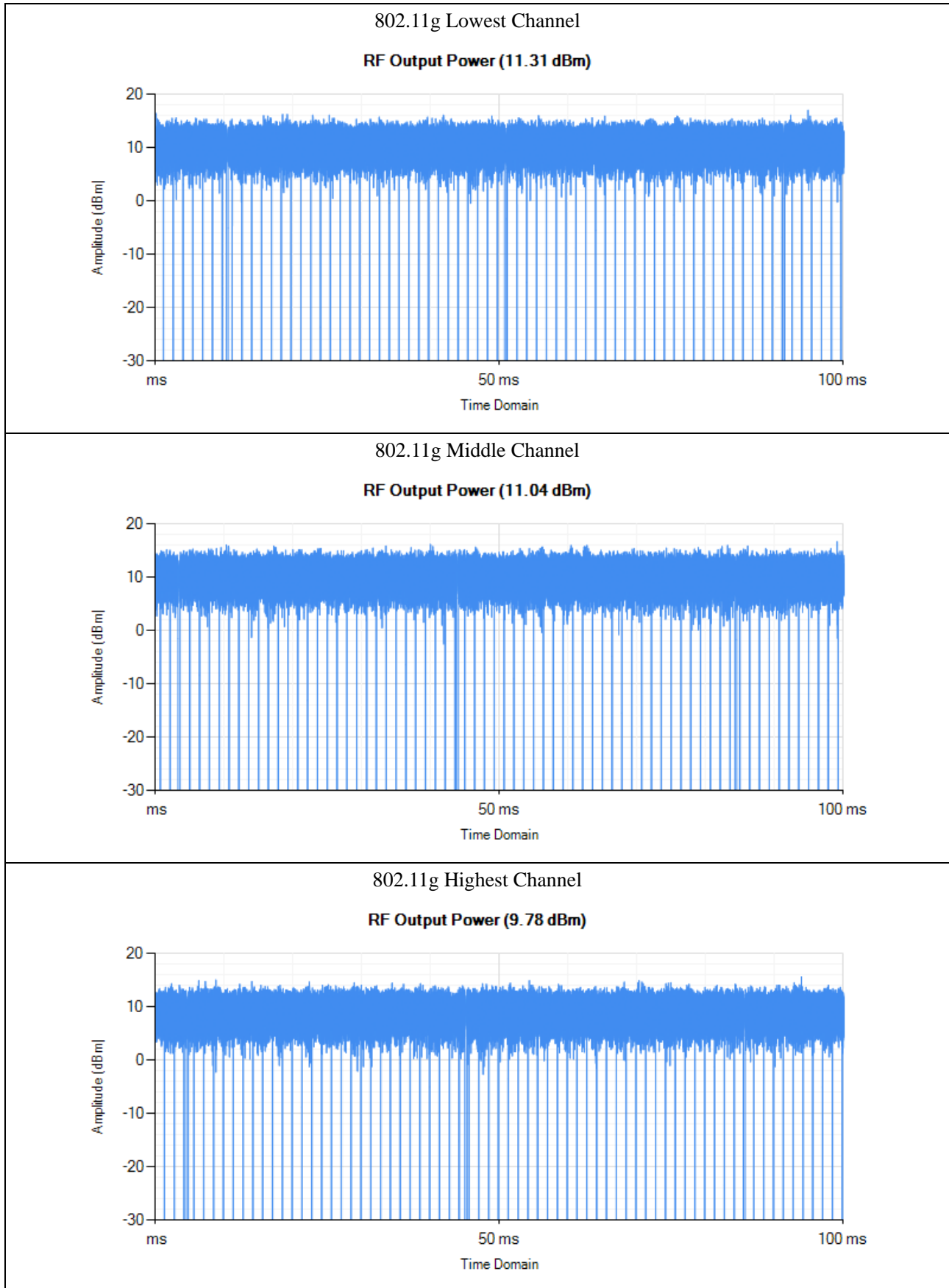

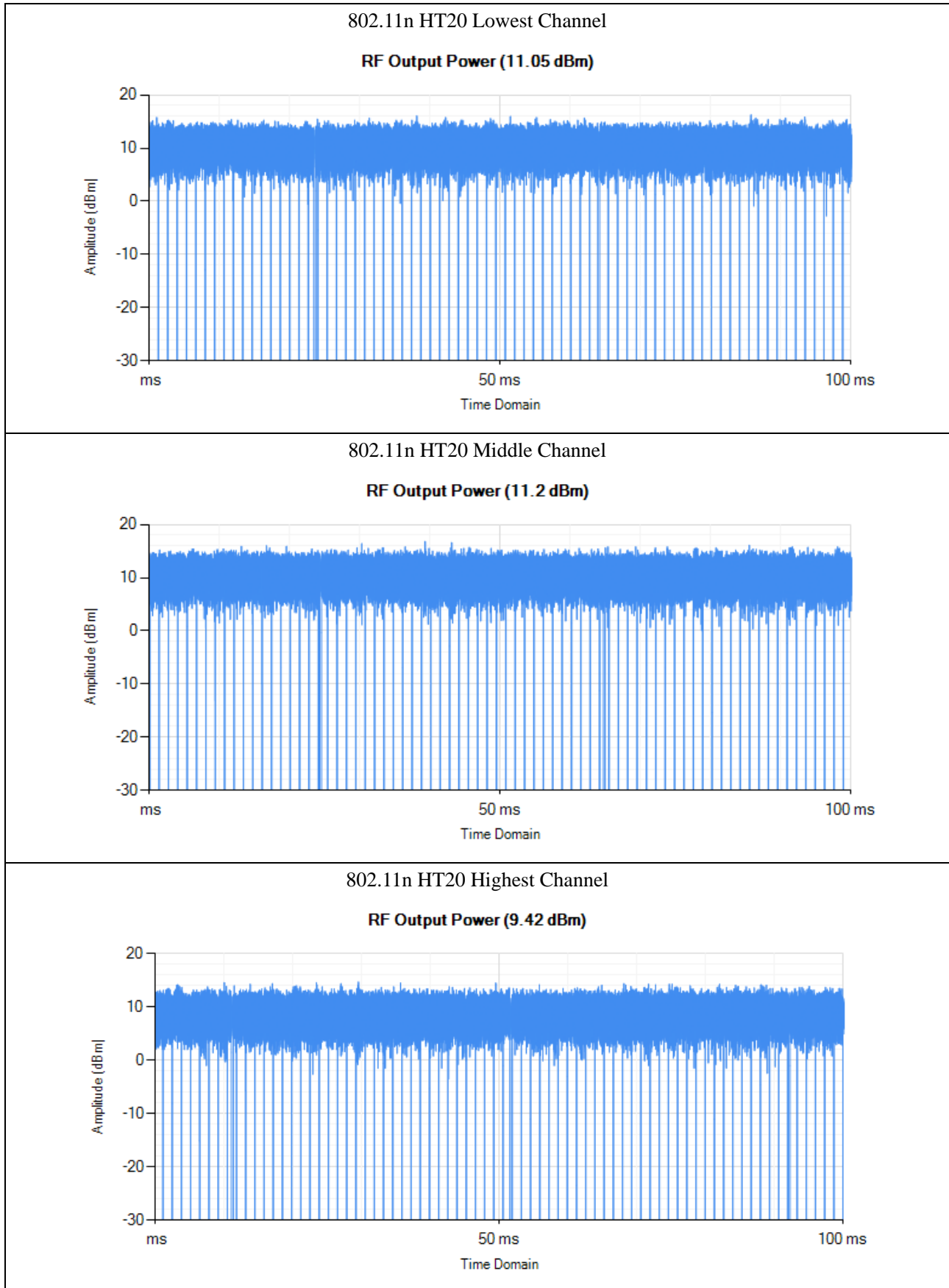

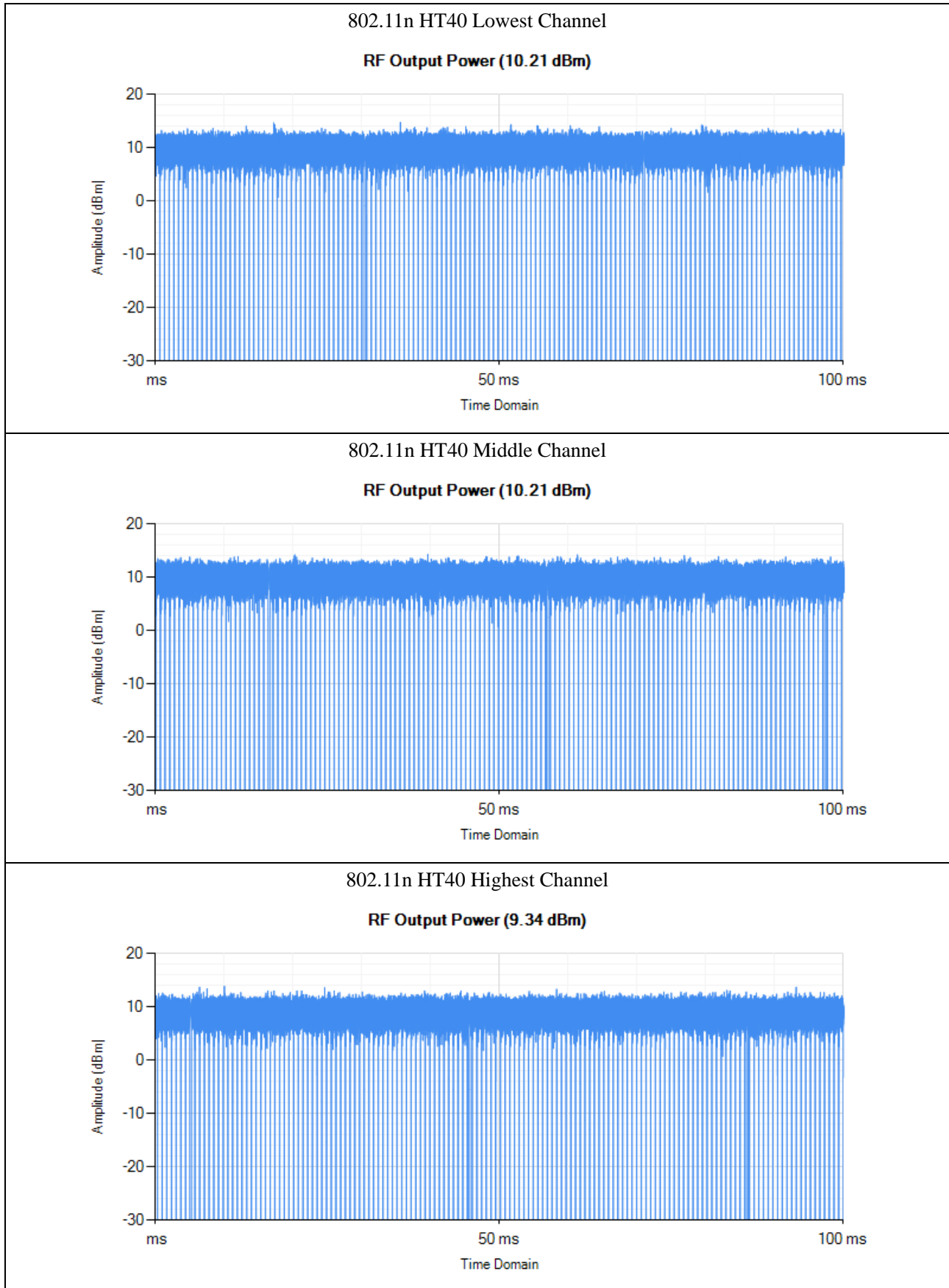

4. Power Spectral Density

4.1 Standard Applicable

According to Section 4.3.2.3.3, For equipment using wide band modulations other than FHSS, the maximum Power Spectral Density is limited to 10 dBm per MHz.

4.2 Test Procedure

According to section 5.3.3.2.1 of the standard EN 300328, the test procedure shall be as follows:

Step 1:

Connect the UUT to the spectrum analyser and use the following settings:

- Start Frequency: 2 400 MHz
- Stop Frequency: 2 483,5 MHz
- Resolution BW: 10 kHz
- Video BW: 30 kHz
- Sweep Points: > 8 350

NOTE: For spectrum analysers not supporting this number of sweep points, the frequency band may be segmented.

- Detector: RMS
- Trace Mode: Max Hold
- Sweep time: Auto

For non-continuous signals, wait for the trace to be completed. Save the (trace) data set to a file.

Step 2:

For conducted measurements on smart antenna systems using either operating mode 2 or 3 (see clause 5.1.3.2), repeat the measurement for each of the transmit ports. For each frequency point, add up the amplitude (power) values for the different transmit chains and use this as the new data set.

Step 3:

Add up the values for amplitude (power) for all the samples in the file.

Step 4:

Normalize the individual values for amplitude so that the sum is equal to the RF Output Power (e.i.r.p.) measured in clause 5.3.2.

Step 5:

Starting from the first sample in the file (lowest frequency), add up the power of the following samples representing a 1 MHz segment and record the results for power and position (i.e. sample #1 to #100). This is the Power Spectral Density (e.i.r.p.) for the first 1 MHz segment which shall be recorded.

Step 6:

Shift the start point of the samples added up in step 5 by 1 sample and repeat the procedure in step 5 (i.e. sample

#2 to#101).

Step 7:

Repeat step 6 until the end of the data set and record the radiated Power Spectral Density values for each of the 1 MHz segments.

From all the recorded results, the highest value is the maximum Power Spectral Density for the UUT. This value, which shall comply with the limit given in clause 4.3.2.3.3, shall be recorded in the test report.

RBW/VBW=10/30 kHz

4.3 Summary of Test Results

Test Mode	Test Frequency	Spectral Density	Limit
	MHz	dBm/MHz	dBm/MHz
802.11b	2412	5.51	10
	2442	4.90	10
	2472	3.95	10
802.11g	2412	0.89	10
	2442	0.78	10
	2472	-0.12	10
802.11n (HT20)	2412	0.29	10
	2442	0.85	10
	2472	-0.74	10
802.11n (HT40)	2422	-4.44	10
	2442	-3.61	10
	2462	-4.80	10

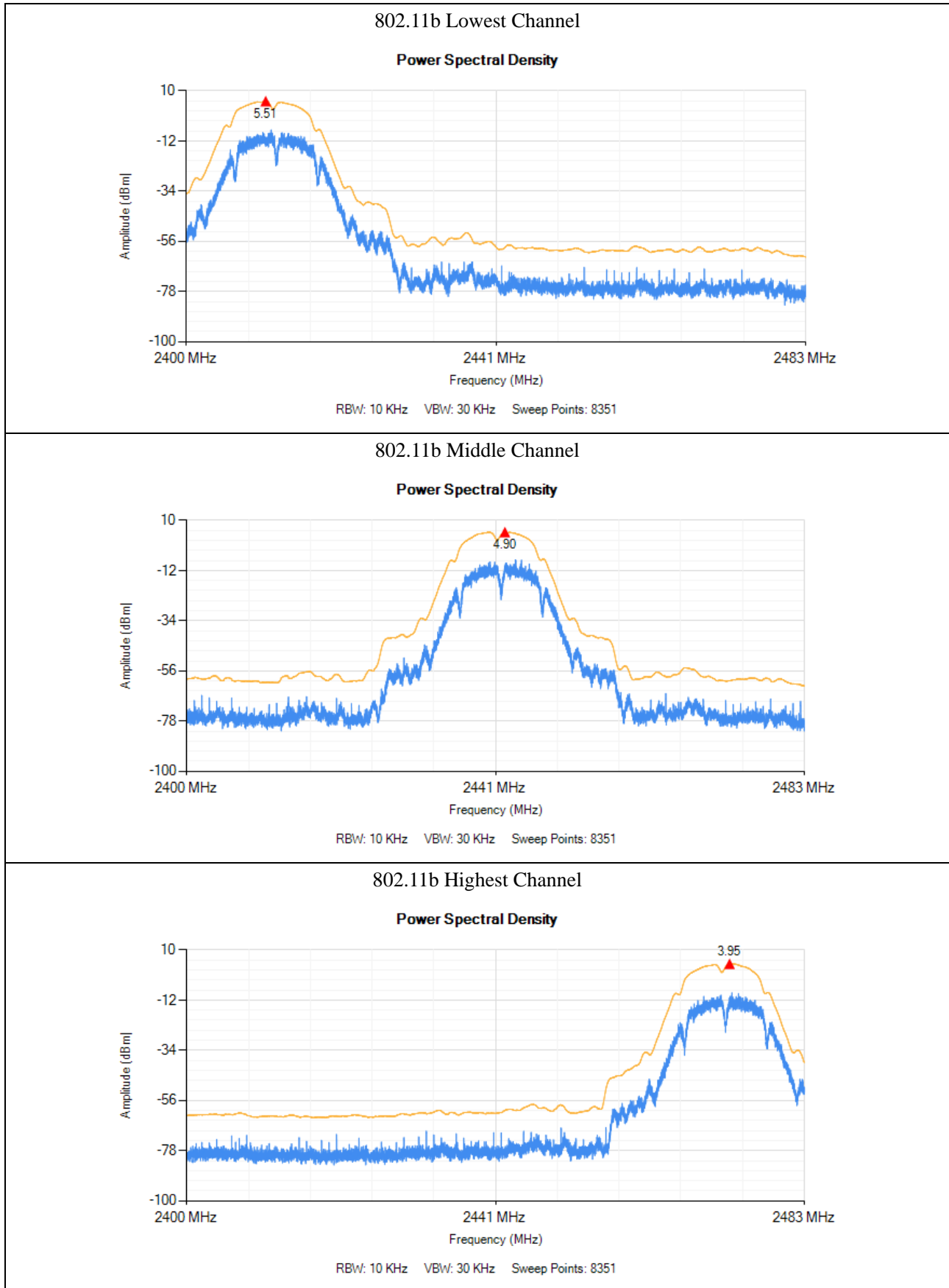

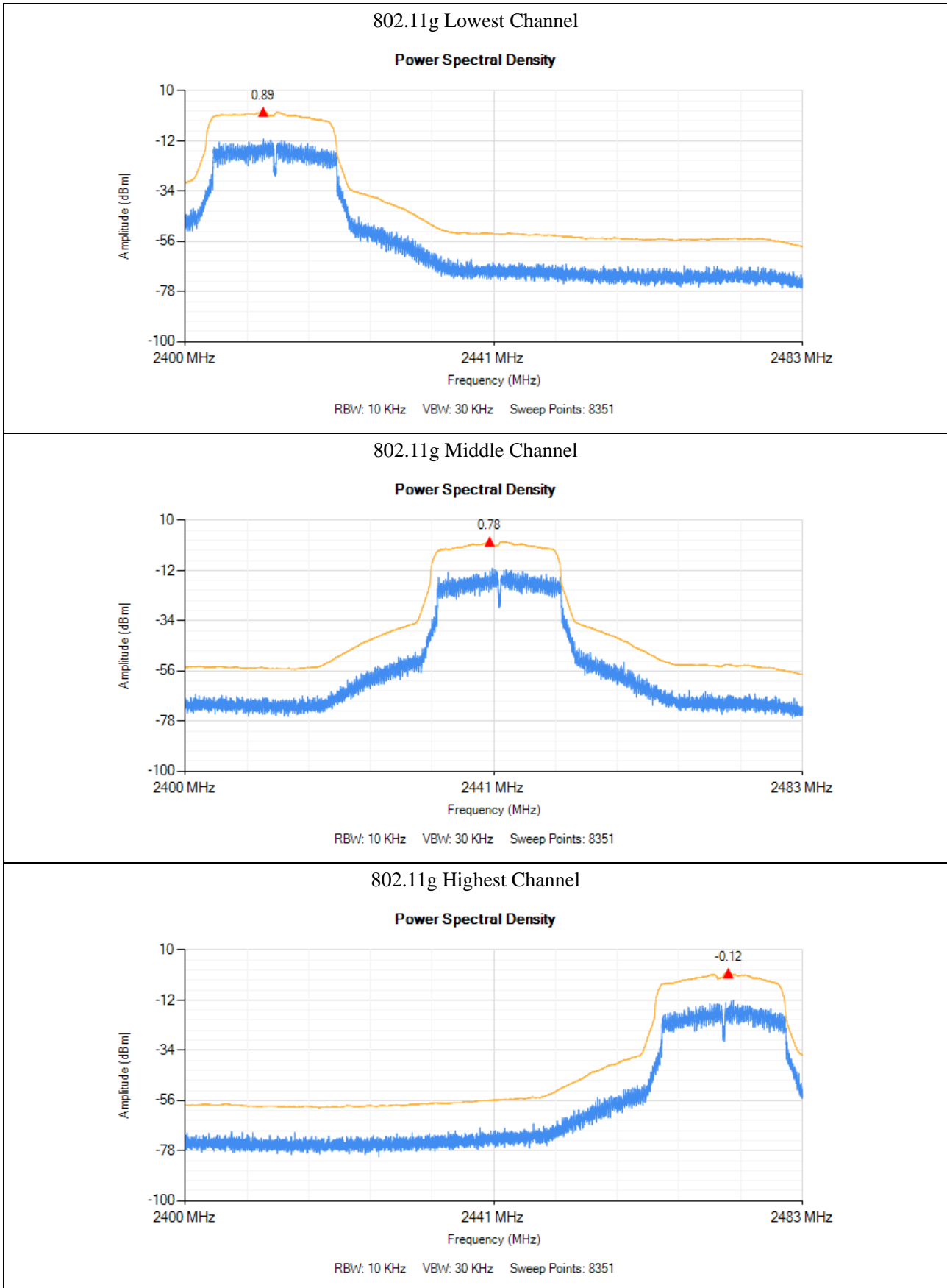

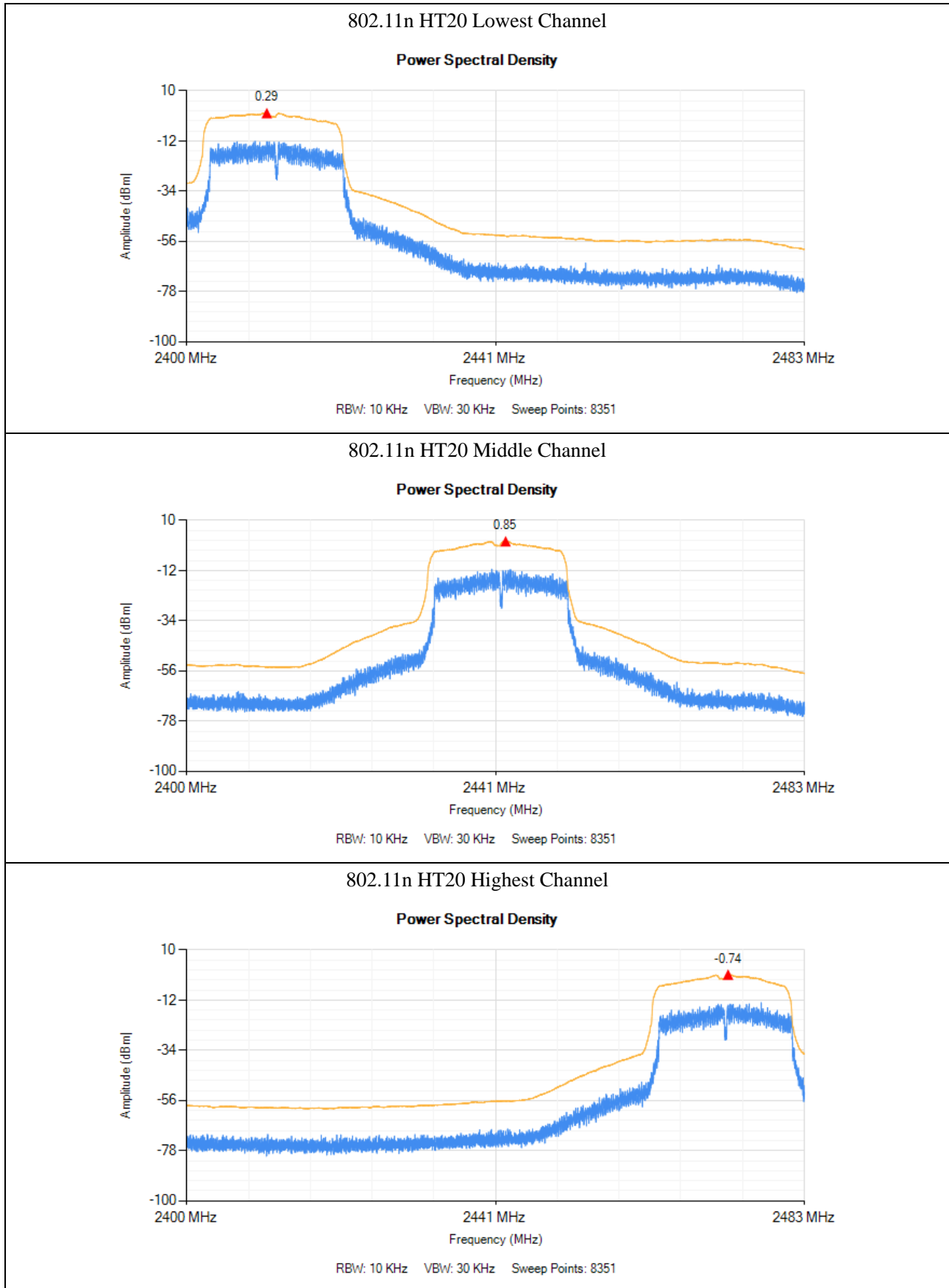

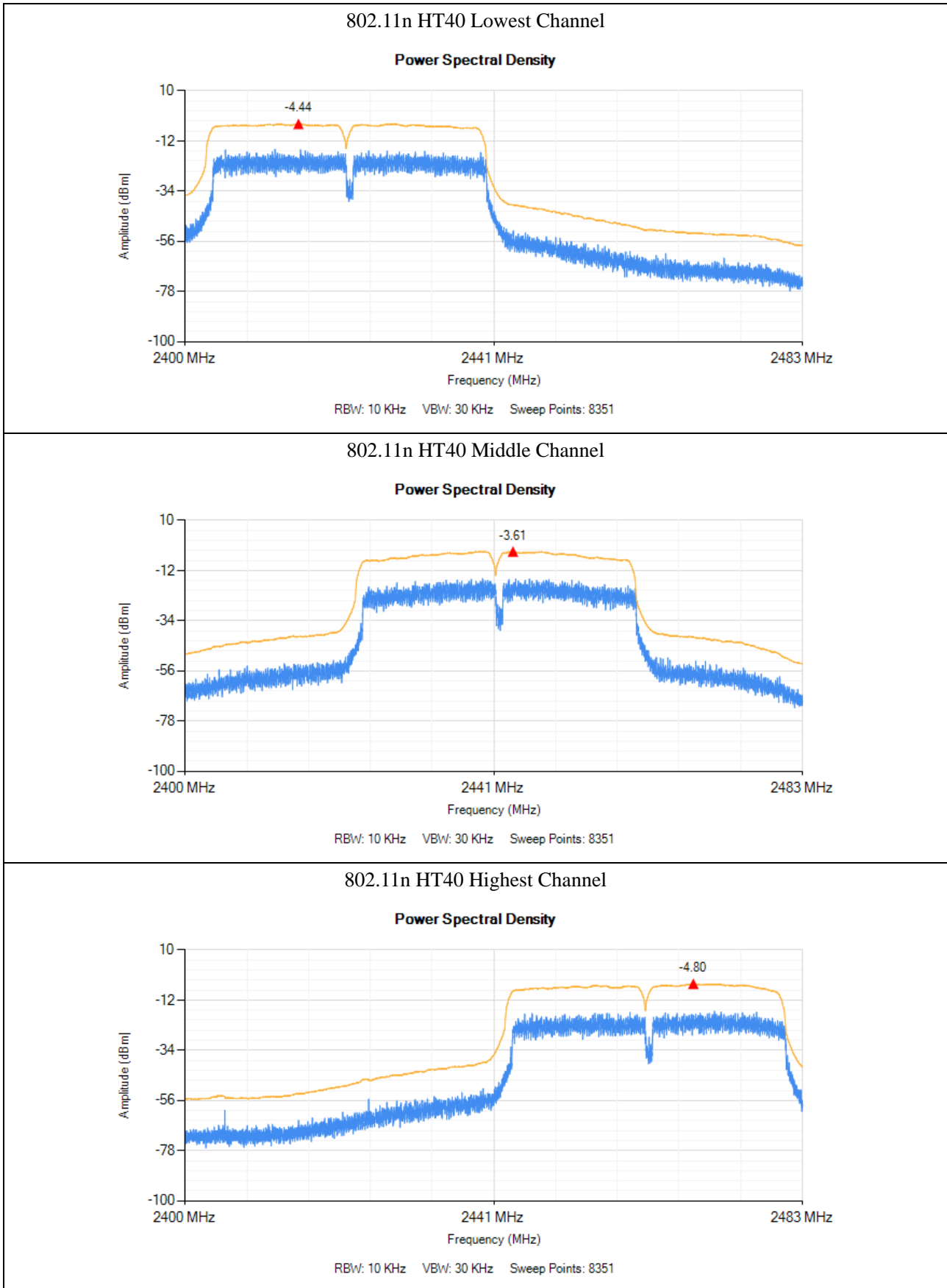

5. Adaptivity and Receiver Blocking

5.1 Standard Application

According to section 4.3.2.6.2.2.2, Load Based Equipment shall comply with the following requirements:

Load Based Equipment may implement an LBT based spectrum sharing mechanism based on the Clear Channel Assessment (CCA) mode using energy detect, as described in IEEE Std. 802.11™-2007 [i.4] clauses 9, 15, 18 or 19, in IEEE Std. 802.11n™-2009 [i.4], clauses 9, 11 and 20 or in IEEE Std. 802.15.4™-2011 [i.5], clauses 4 and 5 providing they comply with the conformance requirements referred to in clause 4.3.2.6.3.2.

Load Based Equipment not using any of the mechanisms referenced above shall comply with the following minimum set of requirements:

1) Before transmission, the equipment shall perform a Clear Channel Assessment (CCA) check using energy detect. The equipment shall observe the operating channel for the duration of the CCA observation time which shall be not less than 18 μ s. The channel shall be considered occupied if the energy level in the channel exceeds the threshold given in step 5) below. If the equipment finds the channel to be clear, it may transmit immediately. See figure 2 below.

2) If the equipment finds the channel occupied, it shall not transmit on this channel during the next Fixed Frame Period.

NOTE 1: The equipment is allowed to switch to a non-adaptive mode and to continue transmissions on this channel providing it complies with the requirements applicable to non-adaptive equipment. See clause 4.3.2.6. Alternatively, the equipment is also allowed to continue Short Control Signalling Transmissions on this channel providing it complies with the requirements given in clause 4.3.2.6.4.

3) The total time during which an equipment has transmissions on a given channel without re-evaluating the availability of that channel, is defined as the Channel Occupancy Time. The Channel Occupancy Time shall be in the range 1 ms to 10 ms followed by an Idle Period of at least 5 % of the Channel Occupancy Time used in the equipment for the current Fixed Frame Period. See figure 2 below.

4) An equipment, upon correct reception of a packet which was intended for this equipment can skip CCA and immediately (see note 2) proceed with the transmission of management and control frames (e.g. ACK and Block ACK frames are allowed but data frames are not allowed). A consecutive sequence of such transmissions by the equipment without a new CCA shall not exceed the maximum Channel Occupancy Time.

NOTE 2: For the purpose of multi-cast, the ACK transmissions (associated with the same data packet) of the individual devices are allowed to take place in a sequence.

5) The energy detection threshold for the CCA shall be proportional to the transmit power of the transmitter: for a 20 dBm e.i.r.p. transmitter the CCA threshold level (TL) shall be equal or less than -70 dBm/MHz at the input to the receiver (assuming a 0 dBi receive antenna). For power levels below 20 dBm e.i.r.p. the CCA threshold level may be relaxed to $TL = -70 \text{ dBm/MHz} + (20 \text{ dBm} - P_{\text{out e.i.r.p.}})/1 \text{ MHz}$ (P_{out} in dBm).

6) Short Control Signalling Transmissions

If implemented, Short Control Signalling Transmissions of adaptive equipment using wide band modulations other than FHSS shall have a maximum duty cycle of 10 % within an observation period of 50 ms.

7) Receiver Blocking

Adaptive equipment using wide band modulations other than FHSS, shall comply with the requirements defined in clauses 4.3.2.6.2 (non-LBT based DAA) or 4.3.2.6.3 (LBT based DAA) in the presence of a blocking signal with characteristics as provided in the follow table.

Receiver Blocking parameters

Table 6: Receiver Blocking parameters

Equipment Type (LBT / non- LBT)	Wanted signal mean power from companion device	Blocking signal frequency [MHz]	Blocking signal power [dBm]	Type of interfering signal
LBT	sufficient to maintain the link (see note 2)	2 395 or 2 488,5 (see note 1)	-35	CW
Non-LBT	-30 dBm			
NOTE 1: The highest blocking frequency shall be used for testing operating channels within the range 2 400 MHz to 2 442 MHz, while the lowest blocking frequency shall be used for testing operating channels within the range 2 442 MHz to 2 483,5 MHz. See clause 5.3.7.1.				
NOTE 2: A typical value which can be used in most cases is -50 dBm/MHz.				

5.2 Test procedure

According to the section 5.3.7.2.1, the test block diagram shall be used.

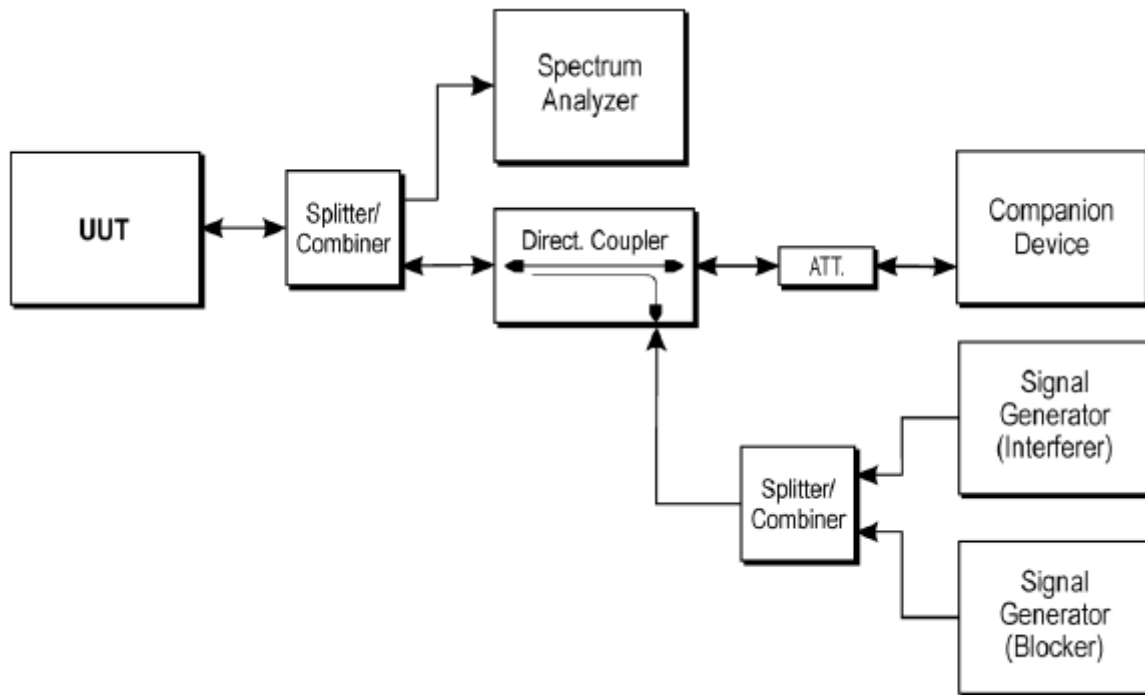

All test procedure is carried to the section 5.3.7.2.1

RBW/VBW=8MHz/30MHz

5.3 Summary of Test Results/Plots

802.11b Lowest Channel (2412MHz)	
AWGN Interference Level (dBm)	-65.00
Block Signal Level (dBm)	-35.00
Max COT Time (ms)	0.36
Interference Start Time (ms)	100
Minimum idle Time (ms)	0.14
Duty Cycle (%)	0
Pulse Width (ms)	0.00
Block Signal Inject time(ms)	200
802.11b Highest Channel (2472MHz)	
AWGN Interference Level (dBm)	-65.00
Block Signal Level (dBm)	-35.00
Max COT Time (ms)	0.16
Interference Start Time (ms)	100
Minimum idle Time (ms)	0.14
Duty Cycle (%)	0
Pulse Width (ms)	0.00
Block Signal Inject time(ms)	200
802.11g Lowest Channel (2412MHz)	
AWGN Interference Level (dBm)	-65.00
Block Signal Level (dBm)	-35.00
Max COT Time (ms)	0.09
Interference Start Time (ms)	100
Minimum idle Time (ms)	0.05
Duty Cycle (%)	0
Pulse Width (ms)	0.00
Block Signal Inject time(ms)	200
802.11g Highest Channel (2472MHz)	
AWGN Interference Level (dBm)	-65.00
Block Signal Level (dBm)	-35.00
Max COT Time (ms)	0.08
Interference Start Time (ms)	100
Minimum Idle Time (ms)	0.06
Duty Cycle (%)	0
Pulse Width (ms)	0.00
Block Signal Inject time(ms)	200

802.1n-HT20 Lowest Channel (2412MHz)	
AWGN Interference Level (dBm)	-65.00
Block Signal Level (dBm)	-35.00
Max COT Time (ms)	0.08
Interference Start Time (ms)	100
Minimum idle Time (ms)	0.06
Duty Cycle (%)	0
Pulse Width (ms)	0.00
Block Signal Inject time(ms)	200
802.11n-HT20 highest Channel (2472MHz)	
AWGN Interference Level (dBm)	-65.00
Block Signal Level (dBm)	-35.00
Max COT Time (ms)	0.09
Interference Start Time (ms)	100
Minimum idle Time (ms)	0.06
Duty Cycle (%)	0
Pulse Width (ms)	0.00
Block Signal Inject time(ms)	200
802.11n-HT40 Lowest Channel (2422MHz)	
AWGN Interference Level (dBm)	-65.00
Block Signal Level (dBm)	-35.00
Max COT Time (ms)	0.06
Interference Start Time (ms)	100
Minimum idle Time (ms)	0.05
Duty Cycle (%)	0
Pulse Width (ms)	0.00
Block Signal Inject time(ms)	200
802.11n-HT40 Highest Channel (2462MHz)	
AWGN Interference Level (dBm)	-65.00
Block Signal Level (dBm)	-35.00
Max COT Time (ms)	0.09
Interference Start Time (ms)	100
Minimum idle Time (ms)	0.07
Duty Cycle (%)	0
Pulse Width (ms)	0.00
Block Signal Inject time(ms)	200

802.11b Lowest Channel (2412MHz)

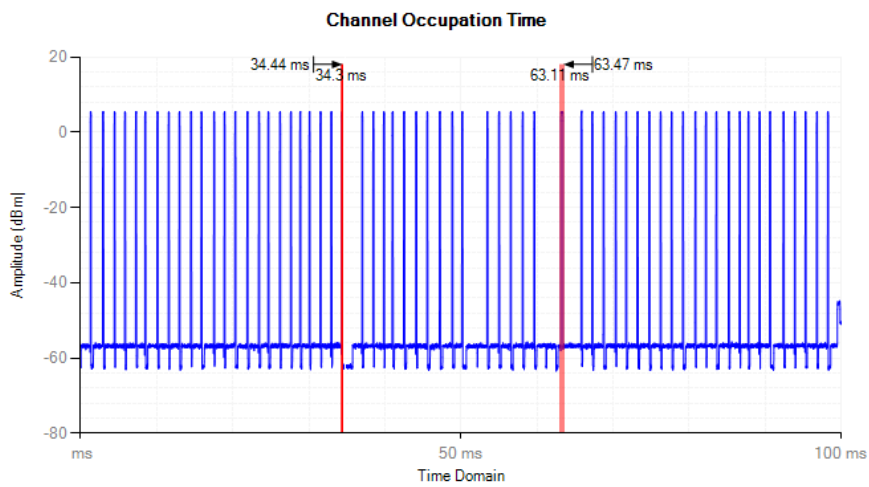
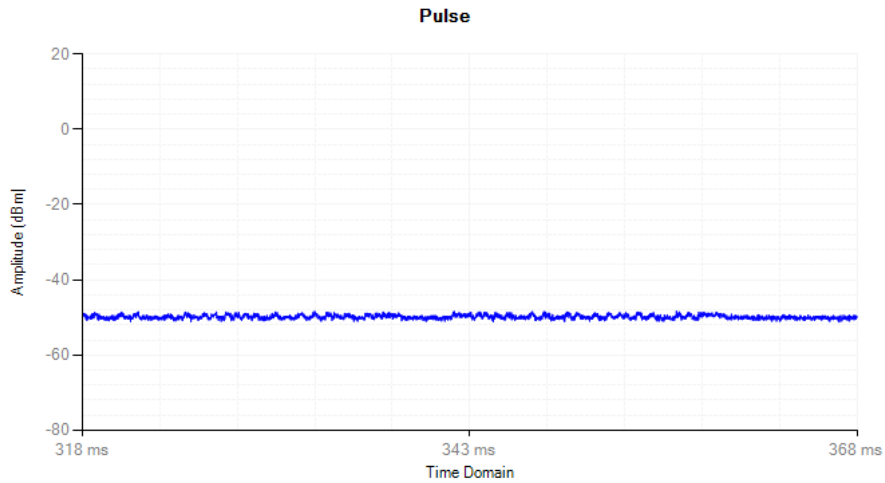
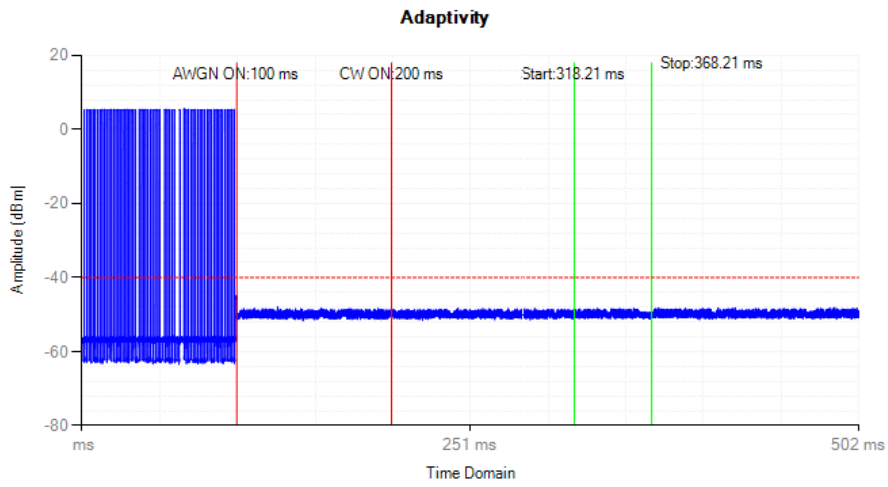

802.11b Highest Channel (2472MHz)

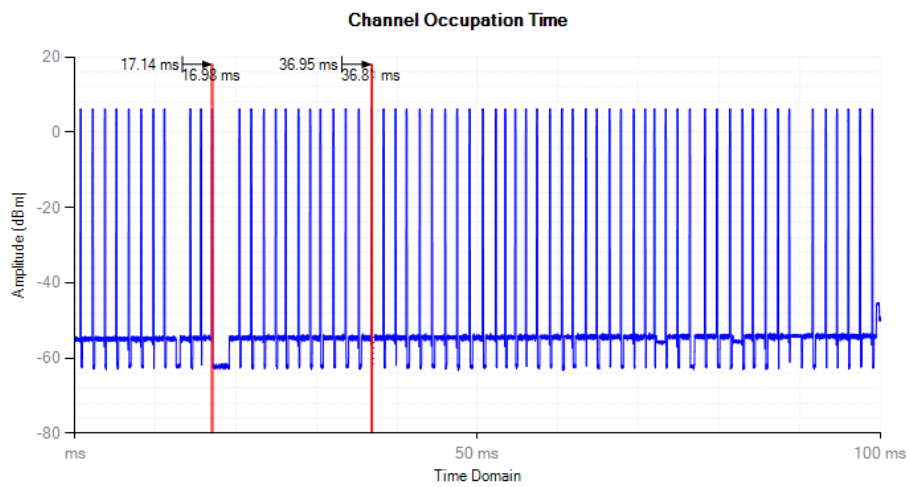
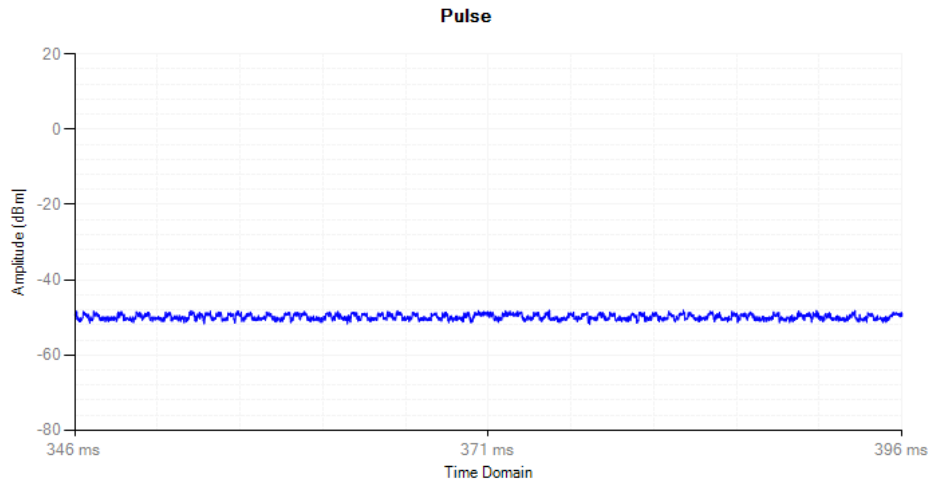
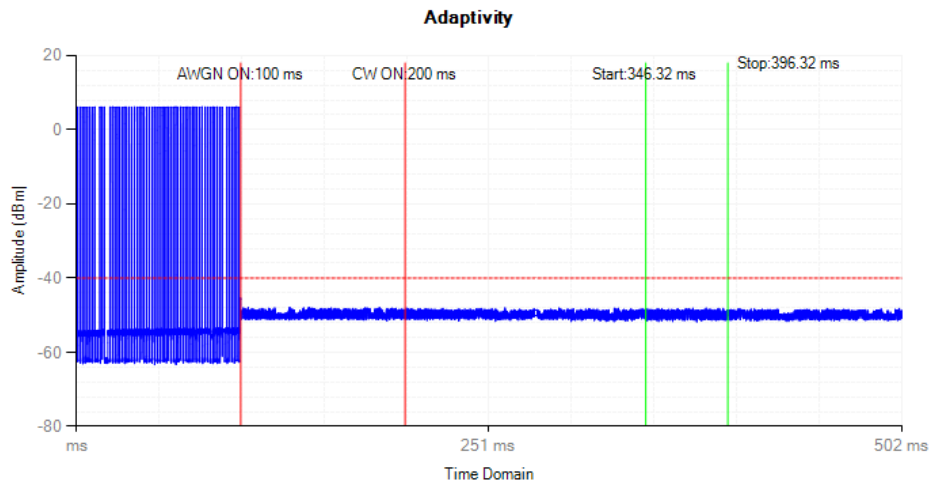

802.11g Lowest Channel (2412MHz)

Adaptivity

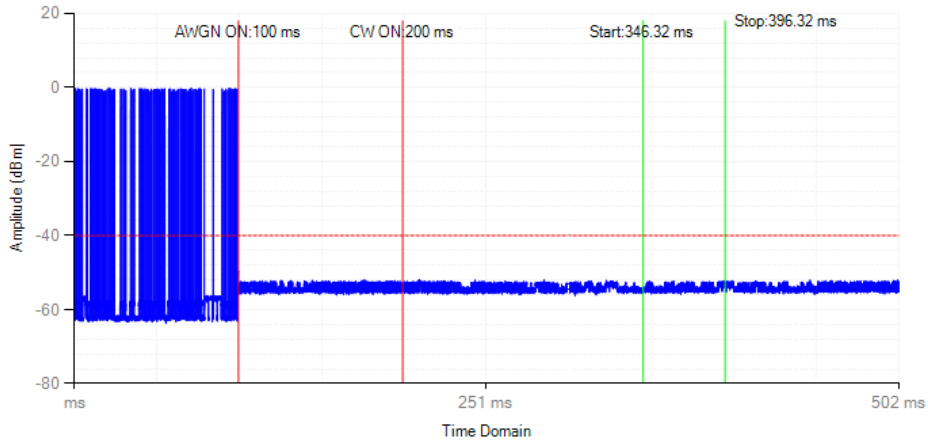

Pulse

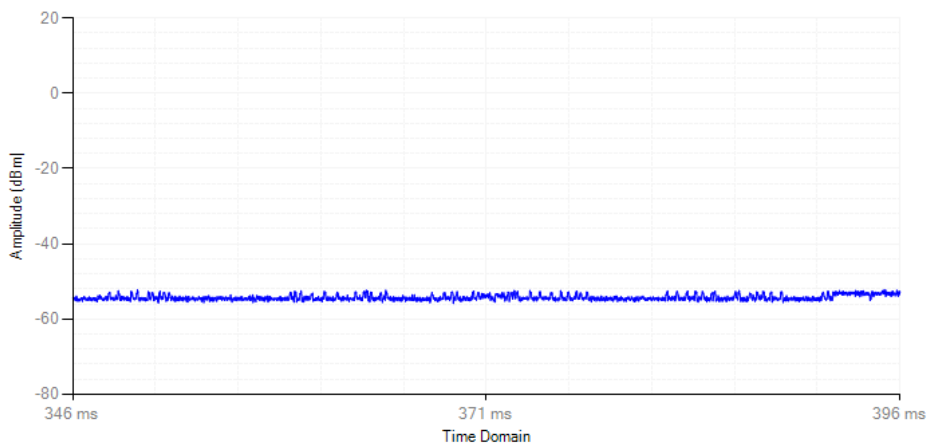

Channel Occupation Time

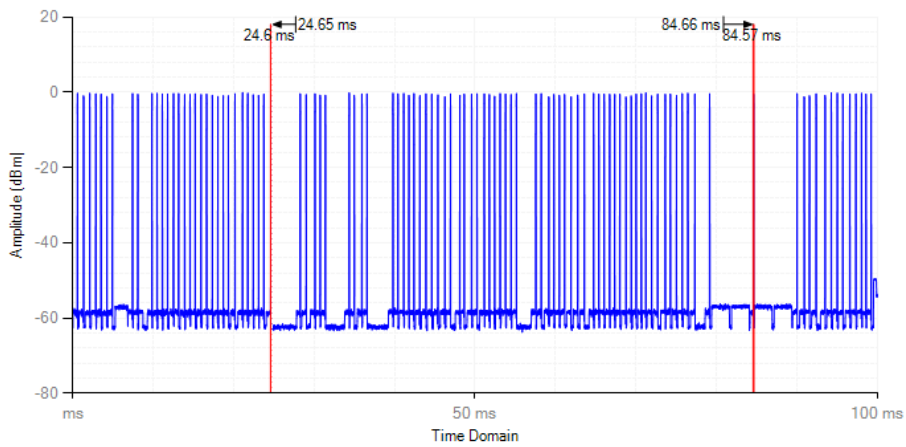

802.11g Highest Channel (2472MHz)

Adaptivity



Pulse

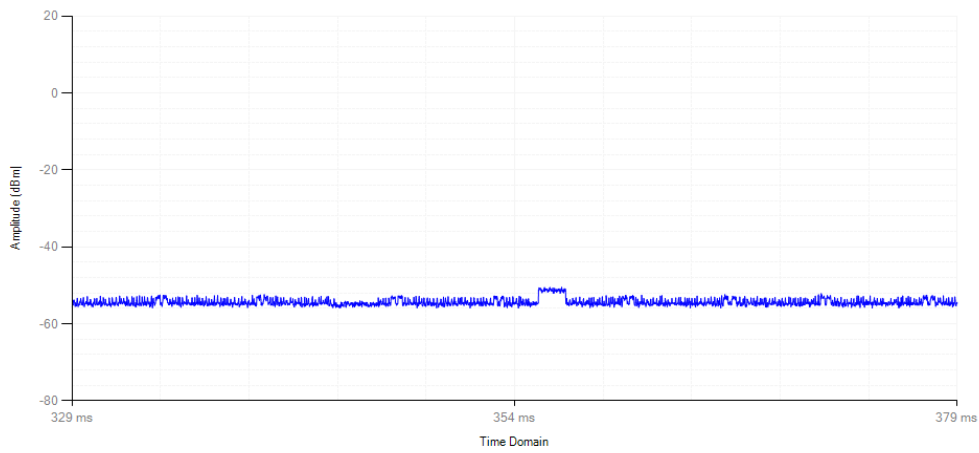

Channel Occupation Time

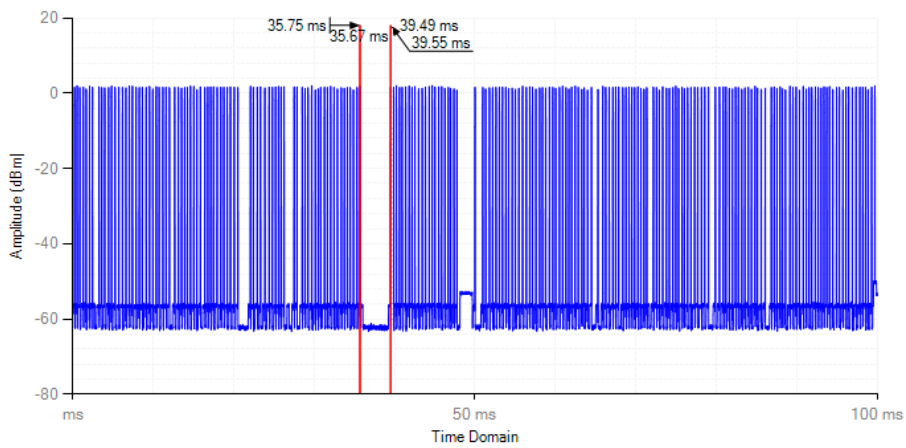

802.1n-HT20 Lowest Channel (2412MHz)

Adaptivity

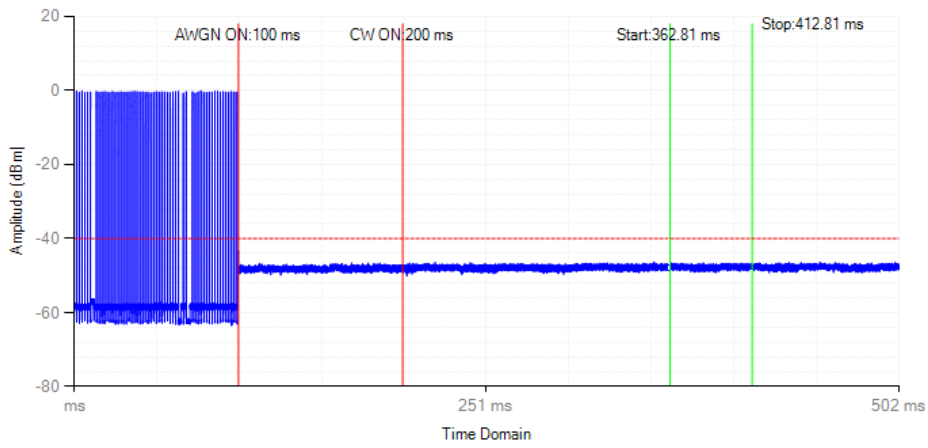

Pulse

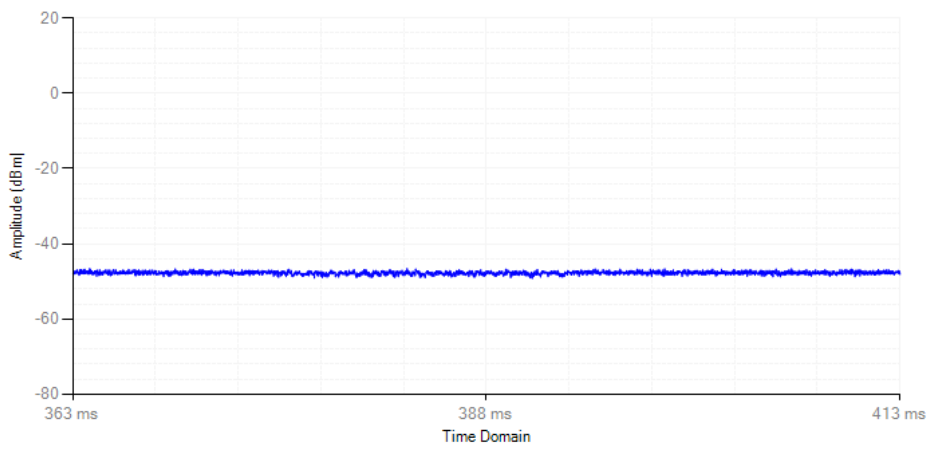

Channel Occupation Time

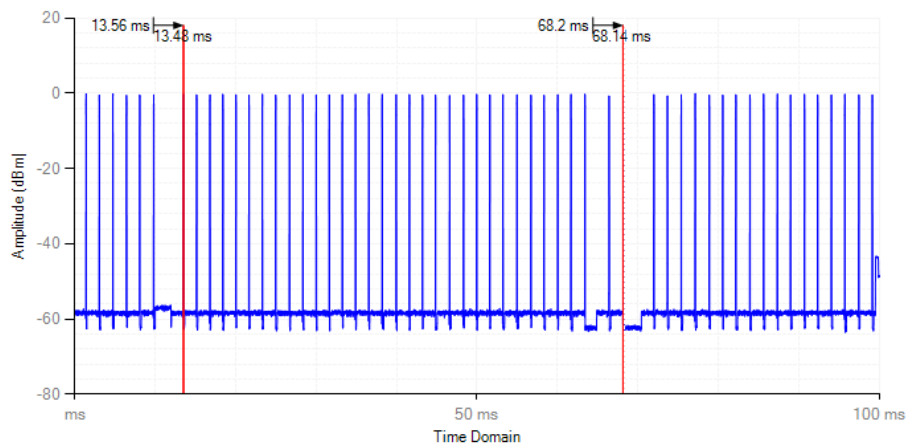

802.11n-HT20 highest Channel (2472MHz)

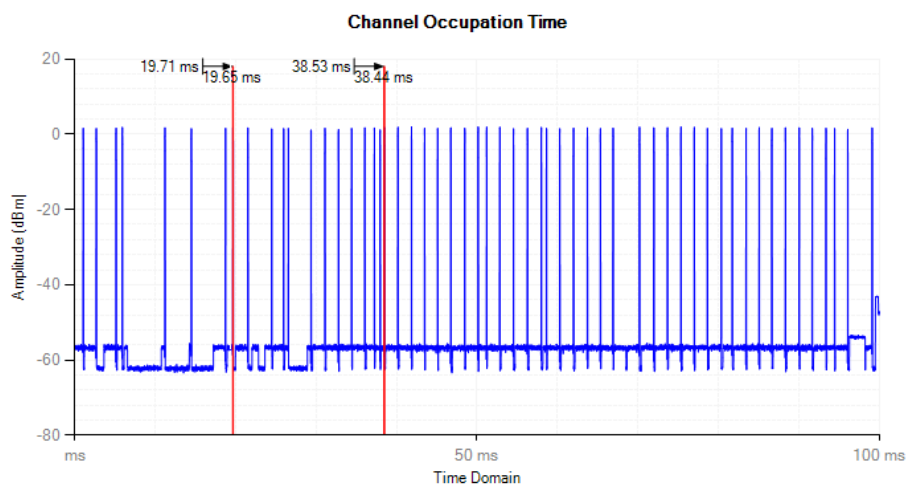
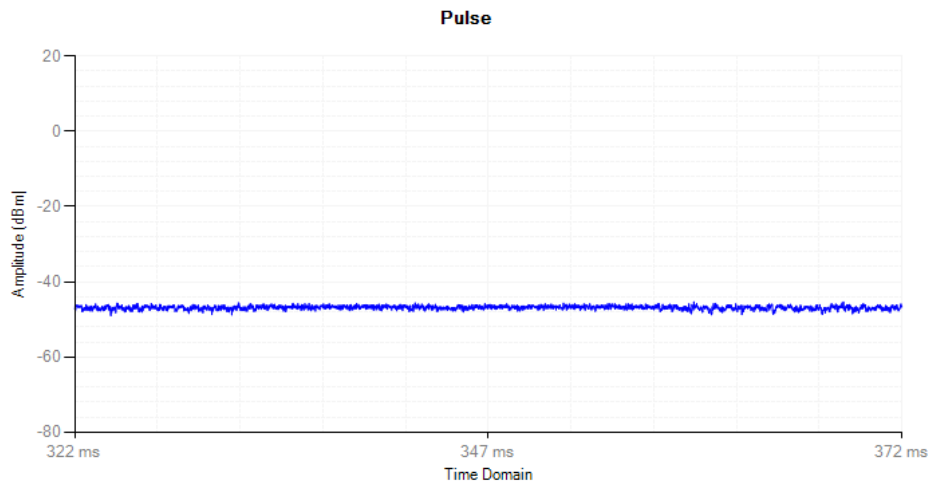
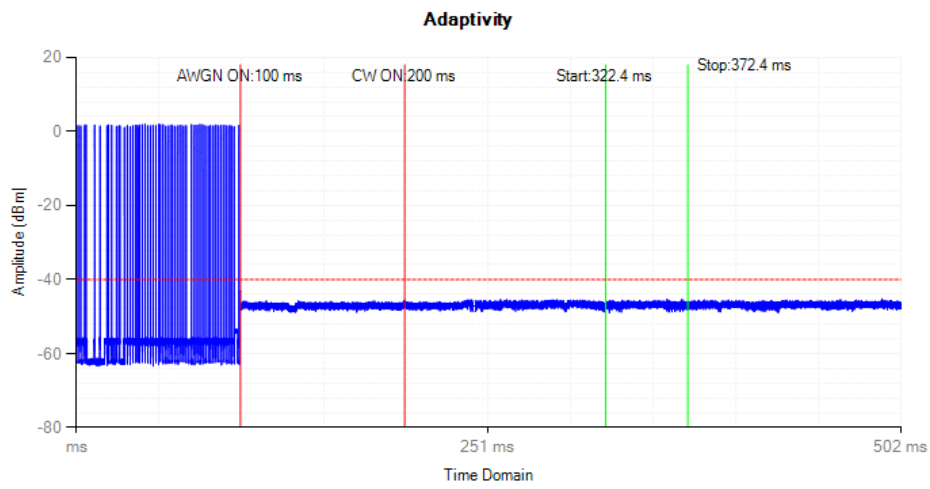

802.11n-HT40 Lowest Channel (2422MHz)

Adaptivity

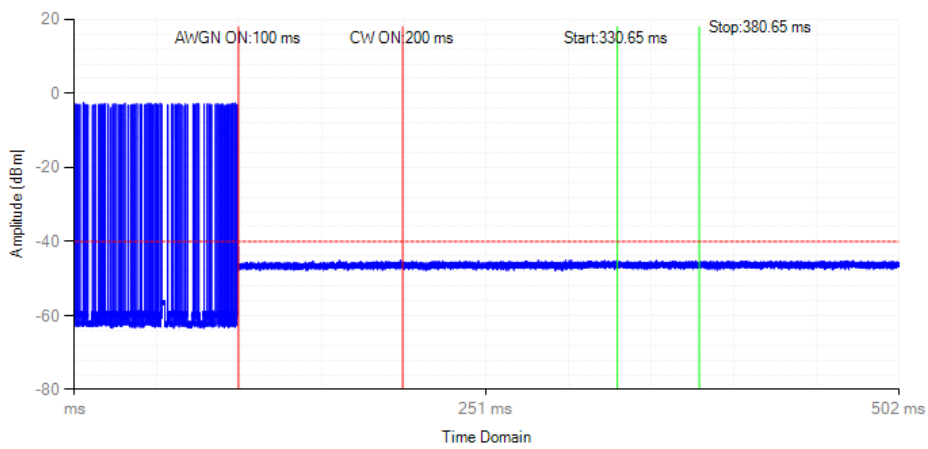

Pulse

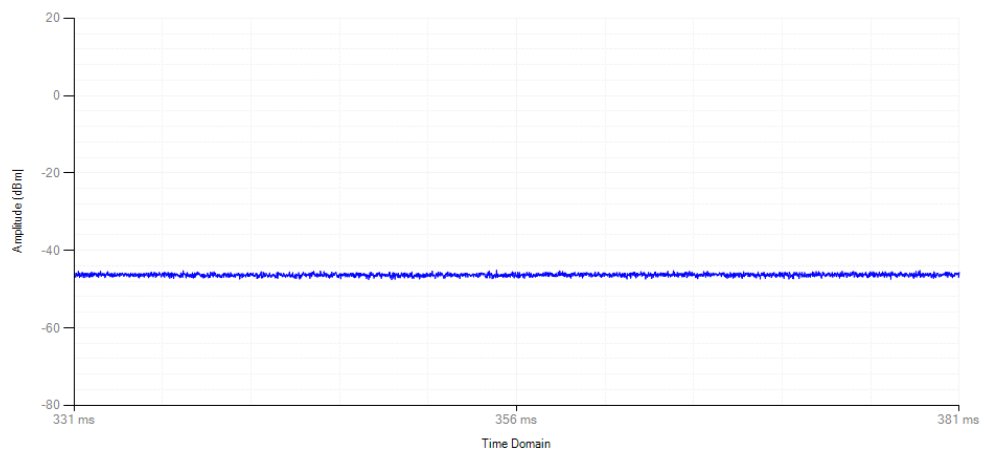

Channel Occupation Time

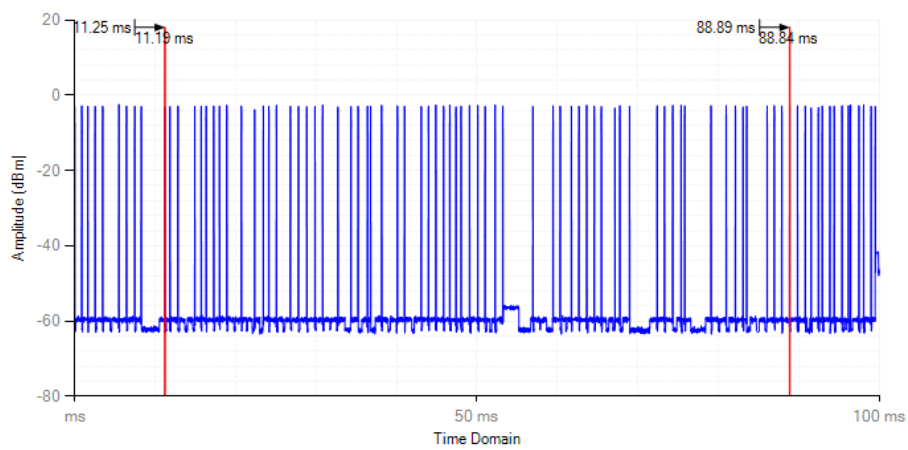

802.11n-HT40 Highest Channel (2462MHz)

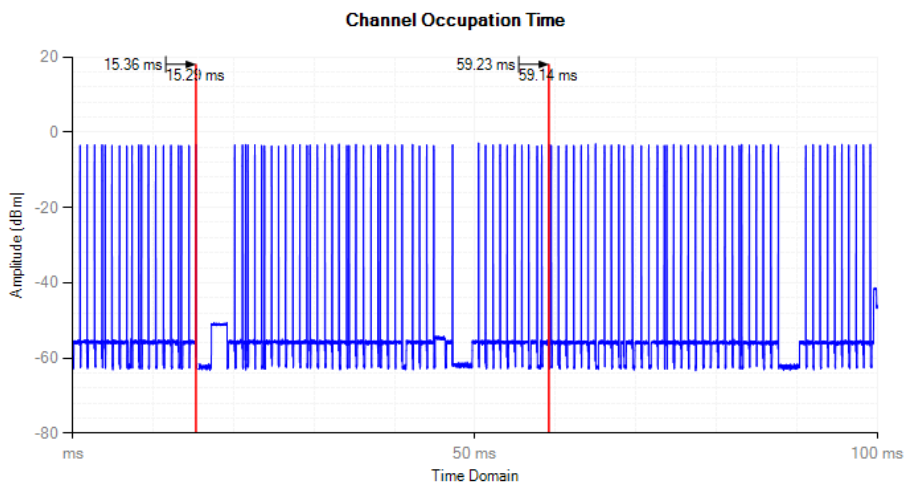
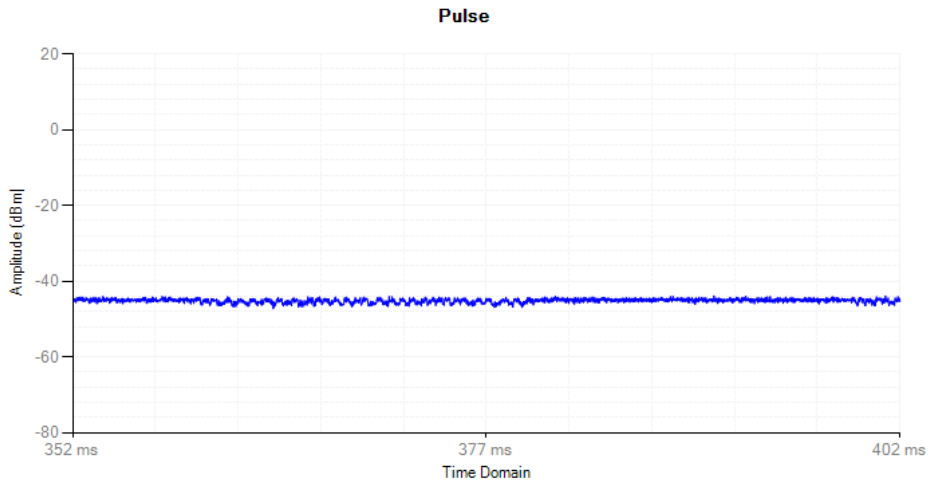
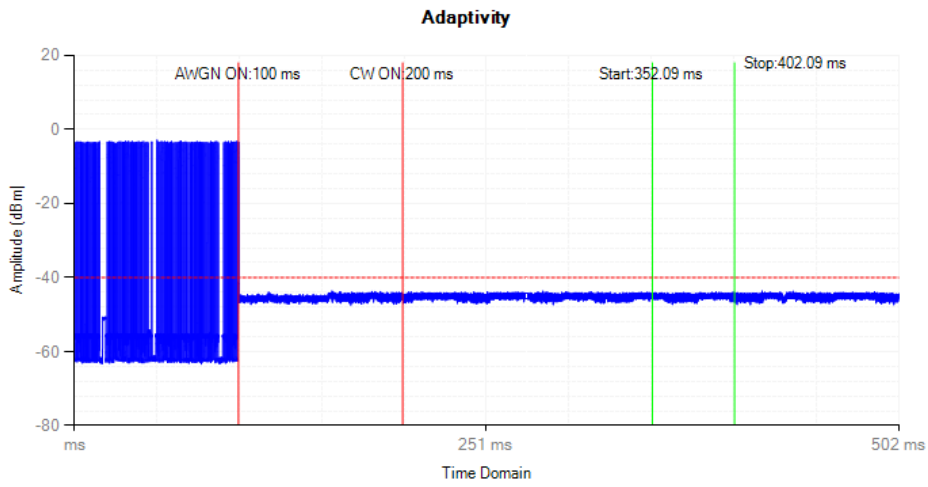

6. Occupied Channel Bandwidth

6.1 Standard Application

According to section 4.3.2.7.3. The Occupied Channel Bandwidth shall fall completely within the band given in clause 1. In addition, for non-adaptive systems using wide band modulations other than FHSS and with e.i.r.p greater than 10 dBm, the occupied channel bandwidth shall be less than 20 MHz.

6.2 Test procedure

According to the section 5.3.8.2.1, the measurement procedure shall be as follows:

Step 1:

Connect the UUT to the spectrum analyser and use the following settings:

- Centre Frequency: The centre frequency of the channel under test
- Resolution BW: ~ 1 % of the span without going below 1 %
- Video BW: 3 × RBW
- Frequency Span: 2 × Occupied Channel Bandwidth
- Detector Mode: RMS
- Trace Mode: Max Hold

Step 2:

Wait until the trace is completed.

Find the peak value of the trace and place the analyser marker on this peak.

Step 3:

Use the 99 % bandwidth function of the spectrum analyser to measure the Occupied Channel Bandwidth of the UUT. This value shall be recorded.

RBW/VBW=430/1200kHz For 802.11b,g,n-HT20

RBW/VBW=820/2400kHz For 802.11n-HT40

6.3 Summary of Test Results/Plots

Test Mode	Test Channel	Measured Value
	MHz	MHz
802.11b	2412	12.67
	2472	12.31
802.11g	2412	16.93
	2472	16.66
802.11n HT20	2412	17.87
	2472	17.59
802.11n HT40	2422	36.43
	2462	36.14

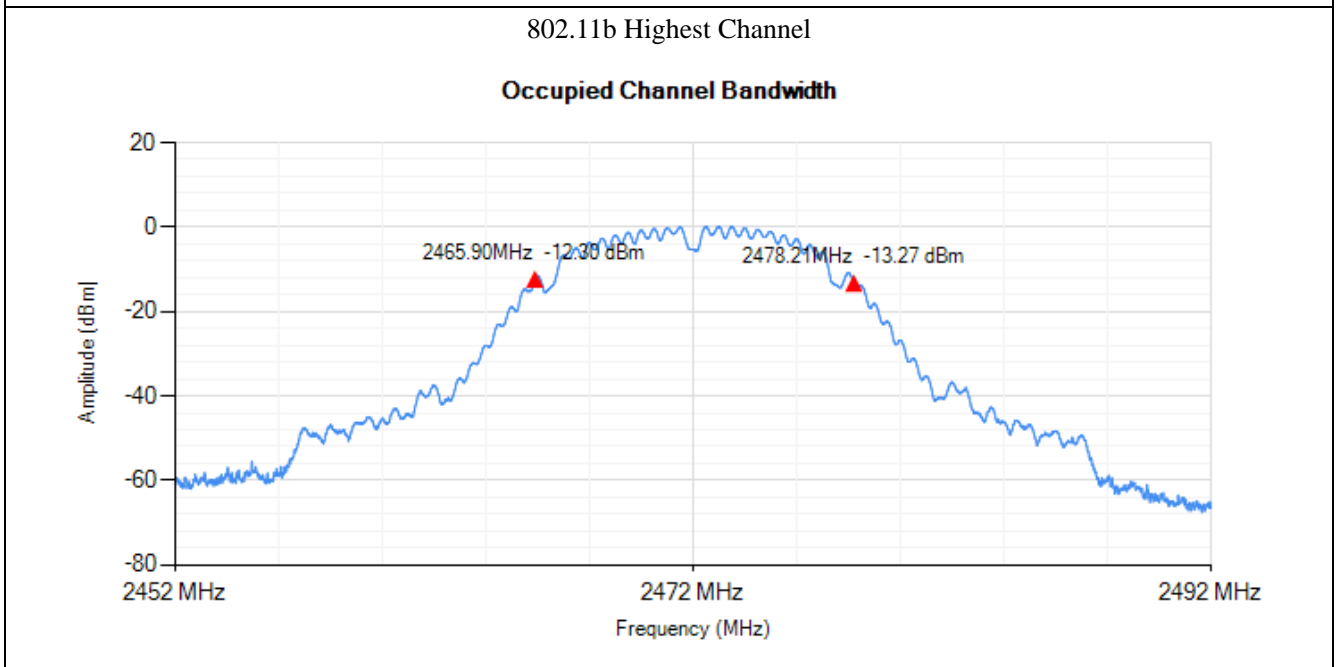
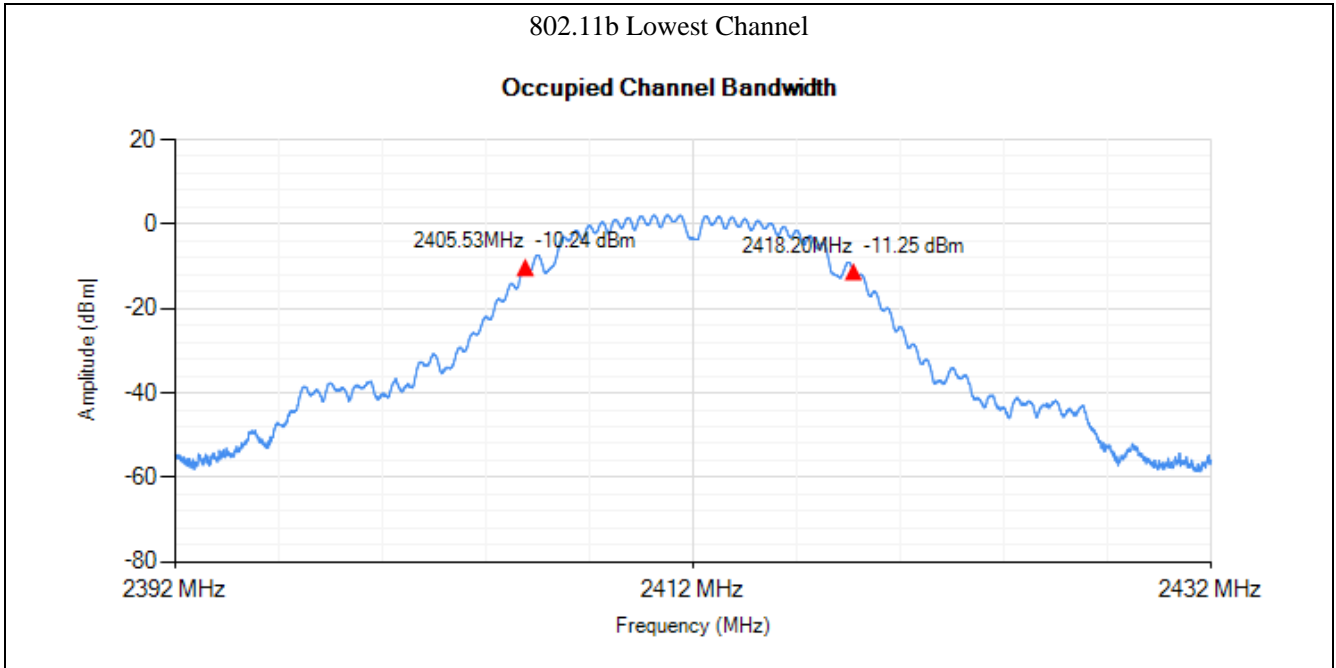

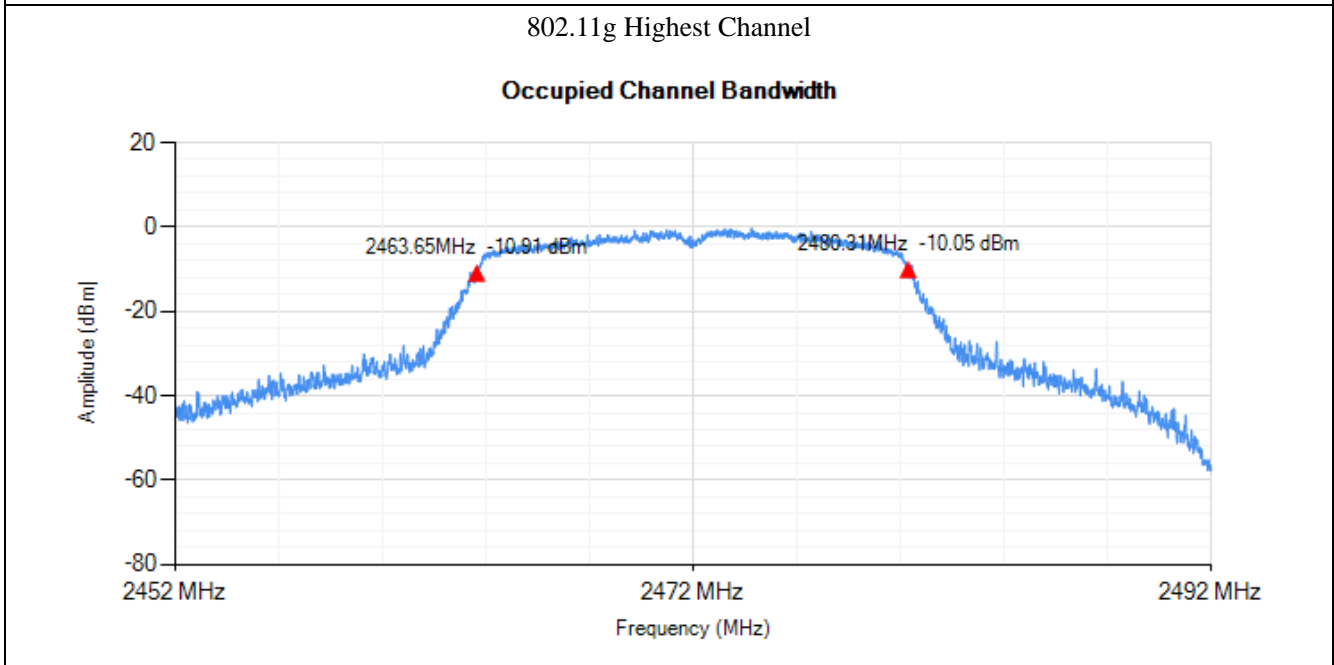
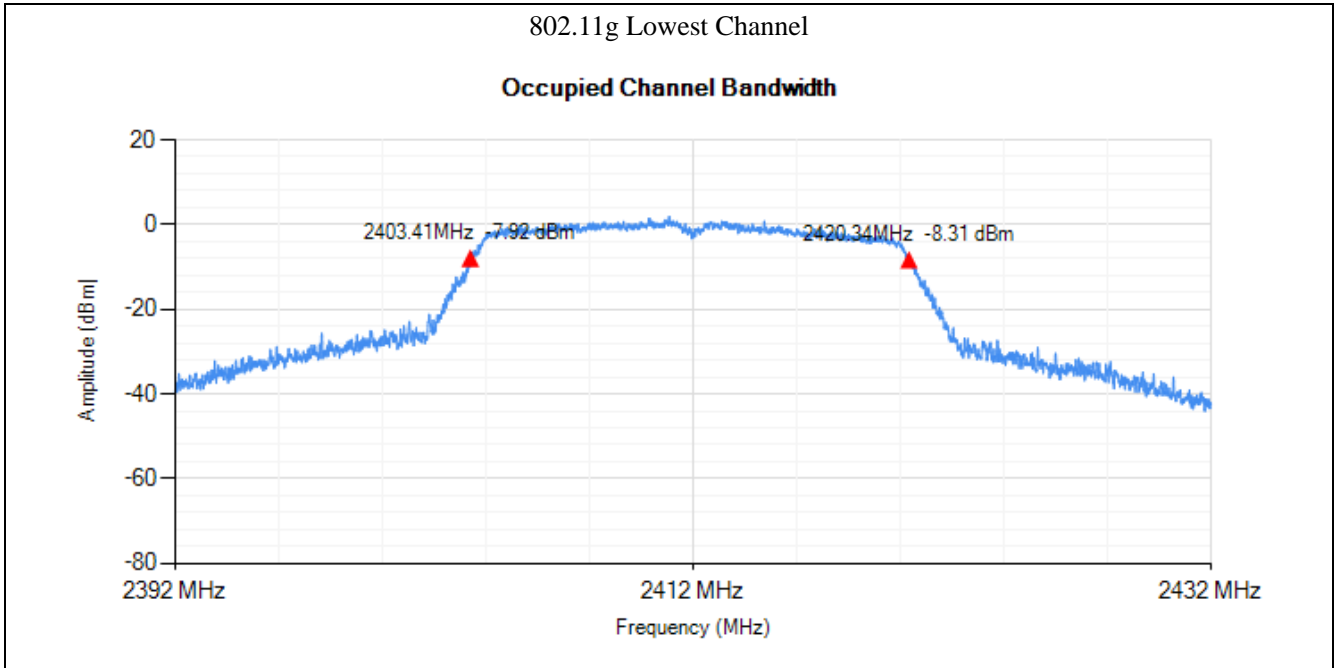

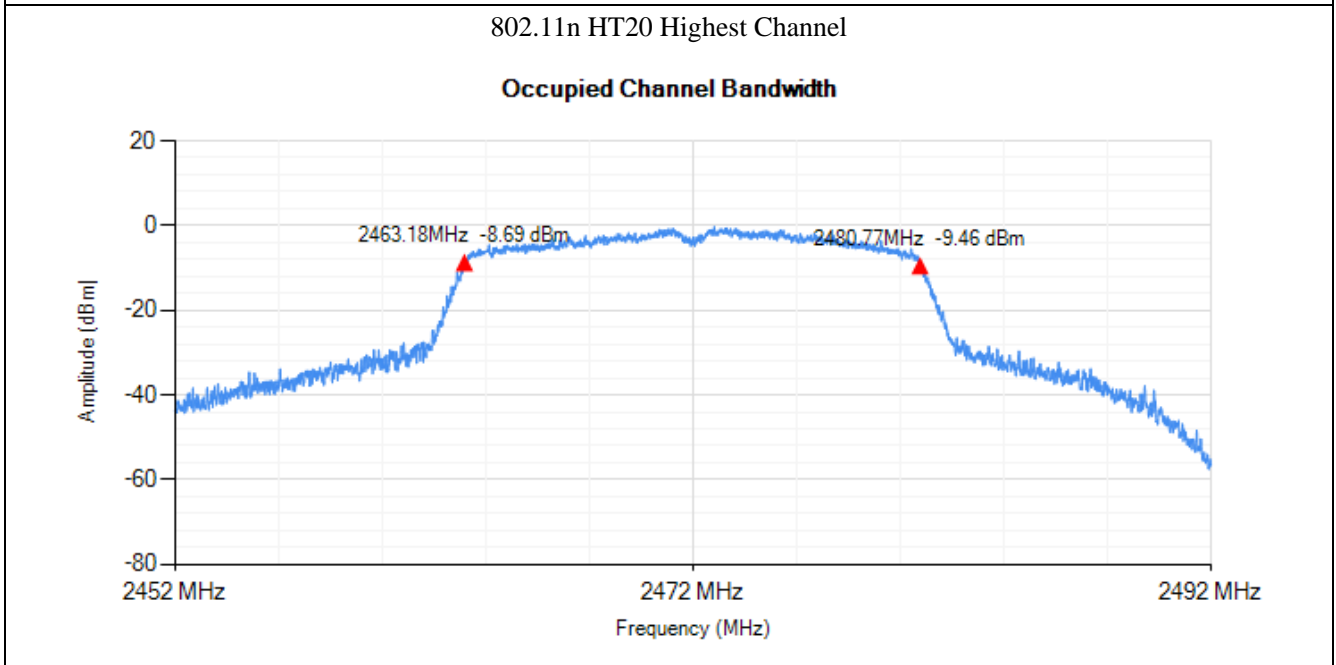
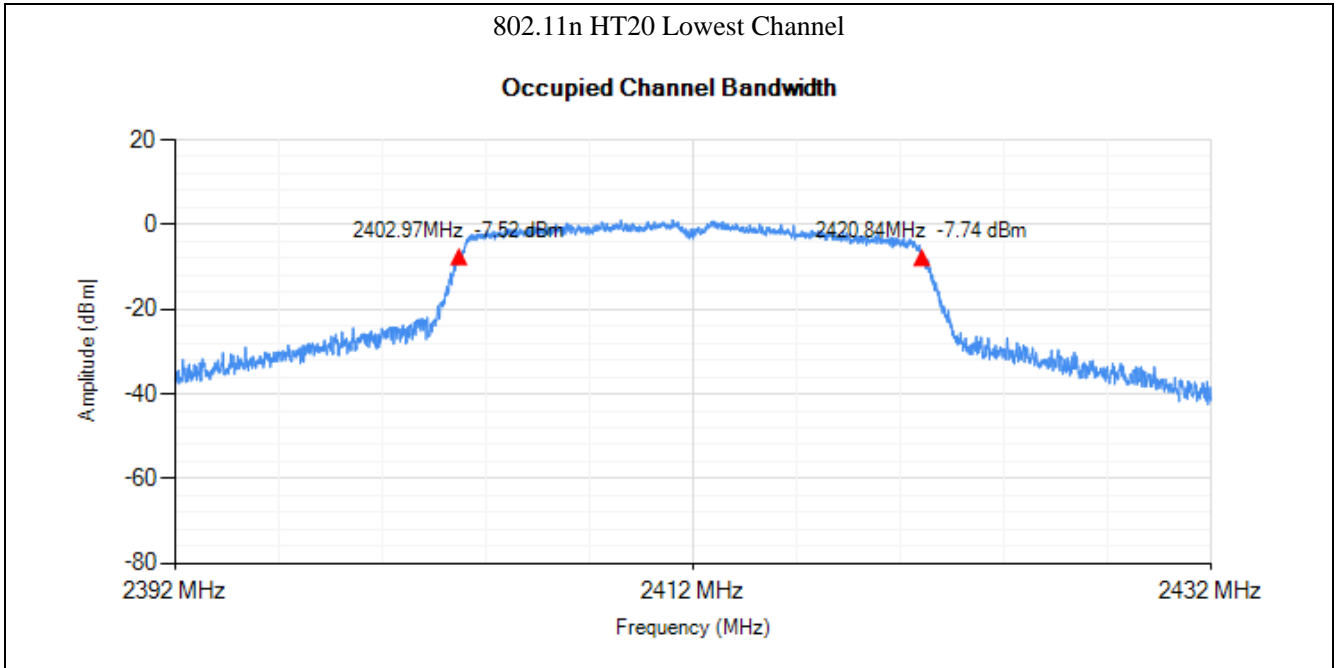

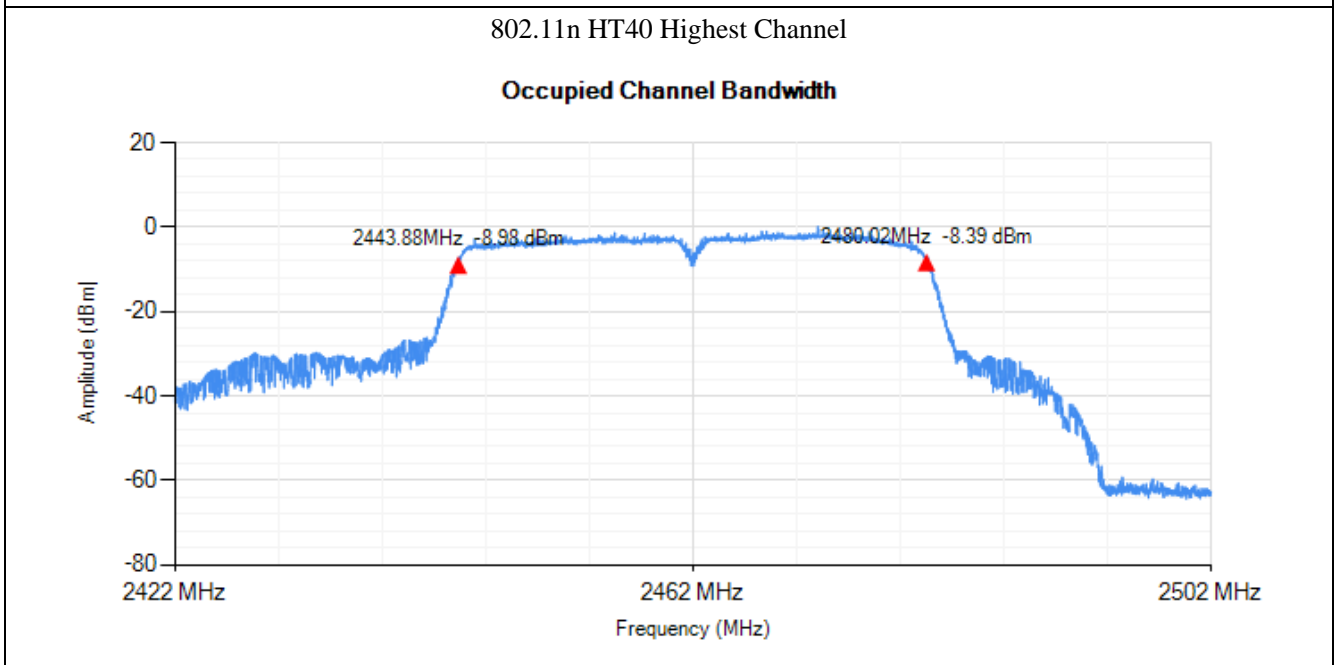
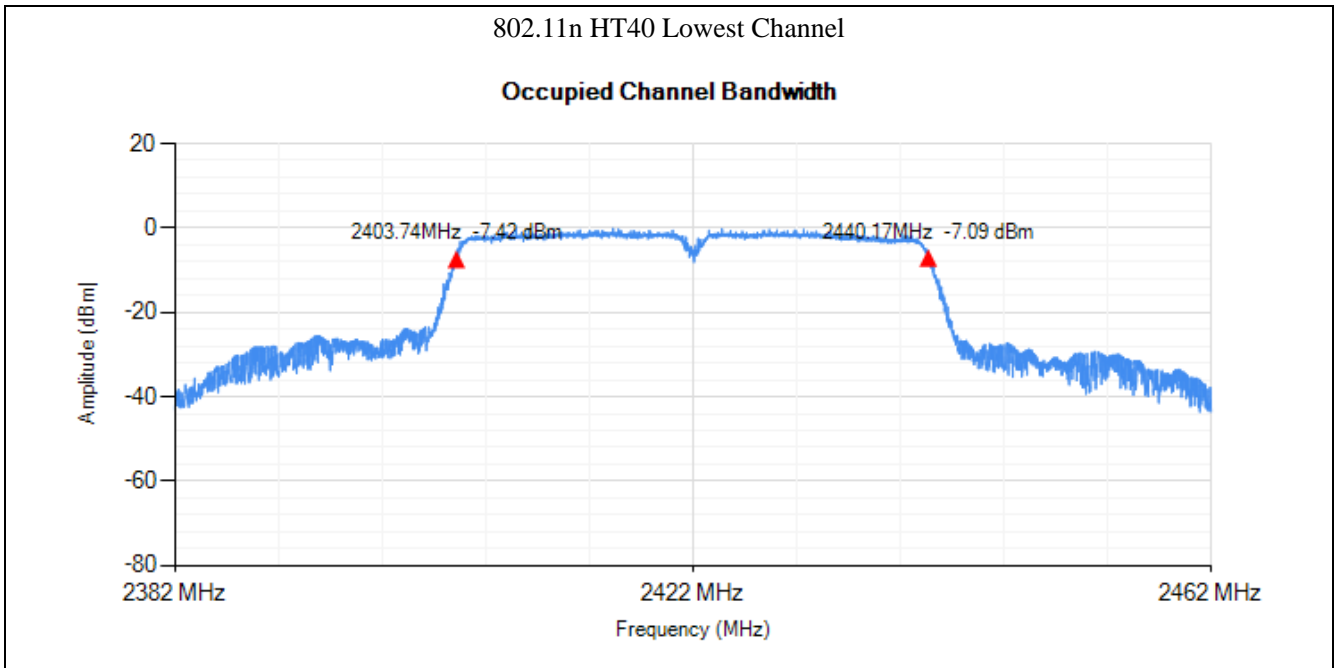

7. Transmitter Unwanted Emissions in the Out-of-band Domain

7.1 Standard Application

According to section 4.3.2.8.3. The transmitter unwanted emissions in the out-of-band domain but outside the allocated band, shall not exceed the values provided by the mask in figure 3.

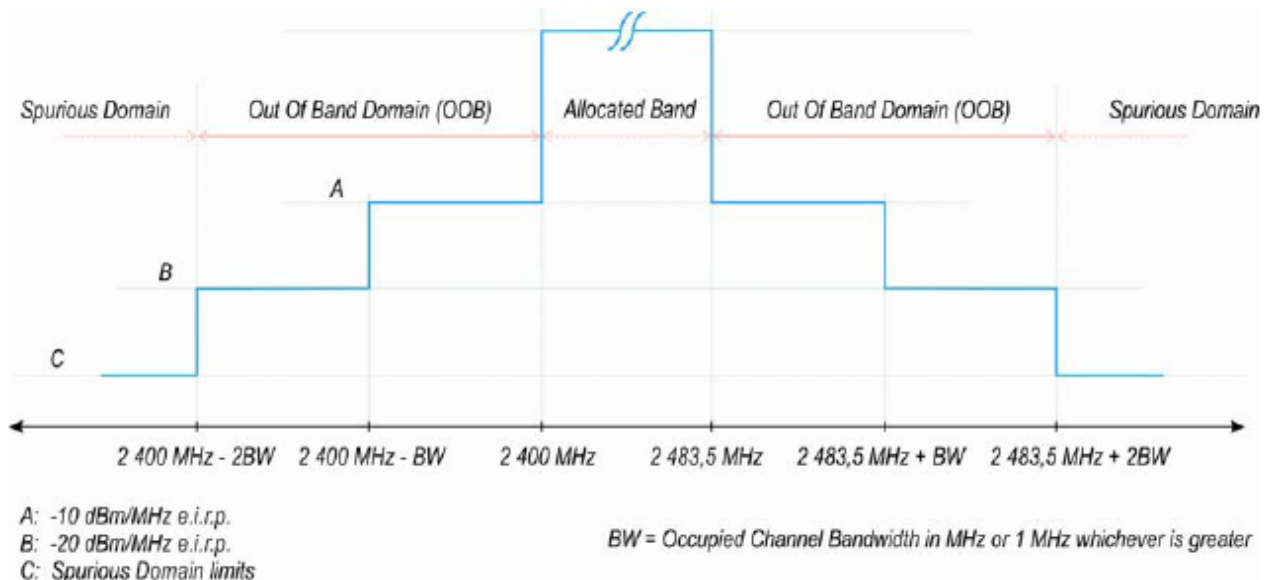

Figure 3: Transmit mask

7.2 Test procedure

According to the section 5.3.9.2.1, the measurement procedure shall be as follows:

The Out-of-band emissions within the different horizontal segments of the mask provided in figures 1 and 3 shall be measured using the steps below. This method assumes the spectrum analyser is equipped with the Time Domain Poweroption.

Step 1:

- Connect the UUT to the spectrum analyser and use the following settings:
 - Centre Frequency: 2 484 MHz
 - Span: 0 Hz
 - Resolution BW: 1 MHz
 - Filter mode: Channel filter
 - Video BW: 3 MHz
 - Detector Mode: RMS
 - Trace Mode: Clear / Write
 - Sweep Mode: Continuous
 - Sweep Points: 5 000
 - Trigger Mode: Video trigger
 - Sweep Time: Suitable to capture one transmission burst

Step 2: (segment 2 483,5 MHz to 2 483,5 MHz + BW)

- Adjust the trigger level to select the transmissions with the highest power level.
- For frequency hopping equipment operating in a normal hopping mode, the different hops will result in signal bursts with different power levels. In this case the burst with the highest power level shall be selected.
- Set a window (start and stop lines) to match with the start and end of the burst and in which the RMS power shall be measured using the Time Domain Power function.
- Select RMS power to be measured within the selected window and note the result which is the RMS power within this 1 MHz segment (2 483,5 MHz to 2 484,5 MHz). Compare this value with the applicable limit provided by the mask.
- Increase the centre frequency in steps of 1 MHz and repeat this measurement for every 1 MHz segment within the range 2 483,5 MHz to 2 483,5 MHz + BW. The centre frequency of the last 1 MHz segment shall be set to 2 483,5 MHz + BW - 0,5 MHz (which means this may partly overlap with the previous 1 MHz segment).

Step 3: (segment 2 483,5 MHz + BW to 2 483,5 MHz + 2BW)

- Change the centre frequency of the analyser to 2 484 MHz + BW and perform the measurement for the first 1 MHz segment within range 2 483,5 MHz + BW to 2 483,5 MHz + 2BW. Increase the centre frequency in 1 MHz steps and repeat the measurements to cover this whole range. The centre frequency of the last 1 MHz segment shall be set to 2 483,5 MHz + 2 BW - 0,5 MHz.

Step 4: (segment 2 400 MHz - BW to 2 400 MHz)

- Change the centre frequency of the analyser to 2 399,5 MHz and perform the measurement for the first 1 MHz segment within range 2 400 MHz - BW to 2 400 MHz. Reduce the centre frequency in 1 MHz steps and repeat the measurements to cover this whole range. The centre frequency of the last 1 MHz segment shall be set to 2 400 MHz - 2BW + 0,5 MHz.

Step 5: (segment 2 400 MHz - 2BW to 2 400 MHz - BW)

- Change the centre frequency of the analyser to 2 399,5 MHz - BW and perform the measurement for the first 1 MHz segment within range 2 400 MHz - 2BW to 2 400 MHz - BW. Reduce the centre frequency in 1 MHz steps and repeat the measurements to cover this whole range. The centre frequency of the last 1 MHz segment shall be set to 2 400 MHz - 2BW + 0,5 MHz.

Step 6:

- In case of conducted measurements on equipment with a single transmit chain, the declared antenna assembly gain "G" in dBi shall be added to the results for each of the 1 MHz segments and compared with the limits provided by the mask given in figures 1 or 3. If more than one antenna assembly is intended for this power setting, the antenna with the highest gain shall be considered.

These measurements have to be performed at normal environmental conditions and shall be repeated at the extremes of the operating temperature range.

RBW/VBW=1MHz/3MHz

7.3 Summary of Test Results/Plots

Test CH.	Test Segment	Max. Emissions Reading (dBm)					Limit
	MHz	Normal	LTLV	LTHV	HTHV	HTLV	dBm
Test Mode: 802.11b							
Lowest	2400-BW to 2400	-31.51	-31.02	-30.53	-30.84	-31.03	-10
	2400-2BW to 2400-BW	-47.56	-46.78	-46.6	-47.46	-46.85	-20
Highest	2483.5 to 2483.5+BW	-41.36	-41.25	-40.47	-40.78	-41.28	-10
	2483.5+BW to 2483.5+2BW	-58.71	-57.76	-57.76	-57.96	-58.5	-20
Test Mode: 802.11g							
Lowest	2400-BW to 2400	-21.75	-21.14	-21.02	-21.51	-21.75	-10
	2400-2BW to 2400-BW	-39.01	-38.63	-38.16	-38.54	-38.32	-20
Highest	2483.5 to 2483.5+BW	-30.71	-29.95	-29.82	-30.15	-30.13	-10
	2483.5+BW to 2483.5+2BW	-63.57	-62.85	-62.92	-63.01	-63.52	-20
Test Mode: 802.11n-HT20							
Lowest	2400-BW to 2400	-21.25	-20.27	-20.66	-20.51	-20.9	-10
	2400-2BW to 2400-BW	-51.06	-50.39	-50.75	-50.69	-51.01	-20
Highest	2483.5 to 2483.5+BW	-29.55	-28.8	-28.68	-28.63	-29.15	-10
	2483.5+BW to 2483.5+2BW	-58.86	-58.09	-58.56	-58.85	-58.62	-20
Test Mode: 802.11n-HT40							
Lowest	2400-BW to 2400	-26.31	-26.28	-26.26	-25.45	-25.48	-10
	2400-2BW to 2400-BW	-34.21	-33.6	-33.29	-33.41	-34.01	-20
Highest	2483.5 to 2483.5+BW	-35.99	-35.9	-35.7	-35.27	-35.92	-10
	2483.5+BW to 2483.5+2BW	-62.95	-62.72	-62.53	-62	-62.32	-20
Note 1: BW please refer to section 6.3.							
Note 2: the data just list the worst cases.							

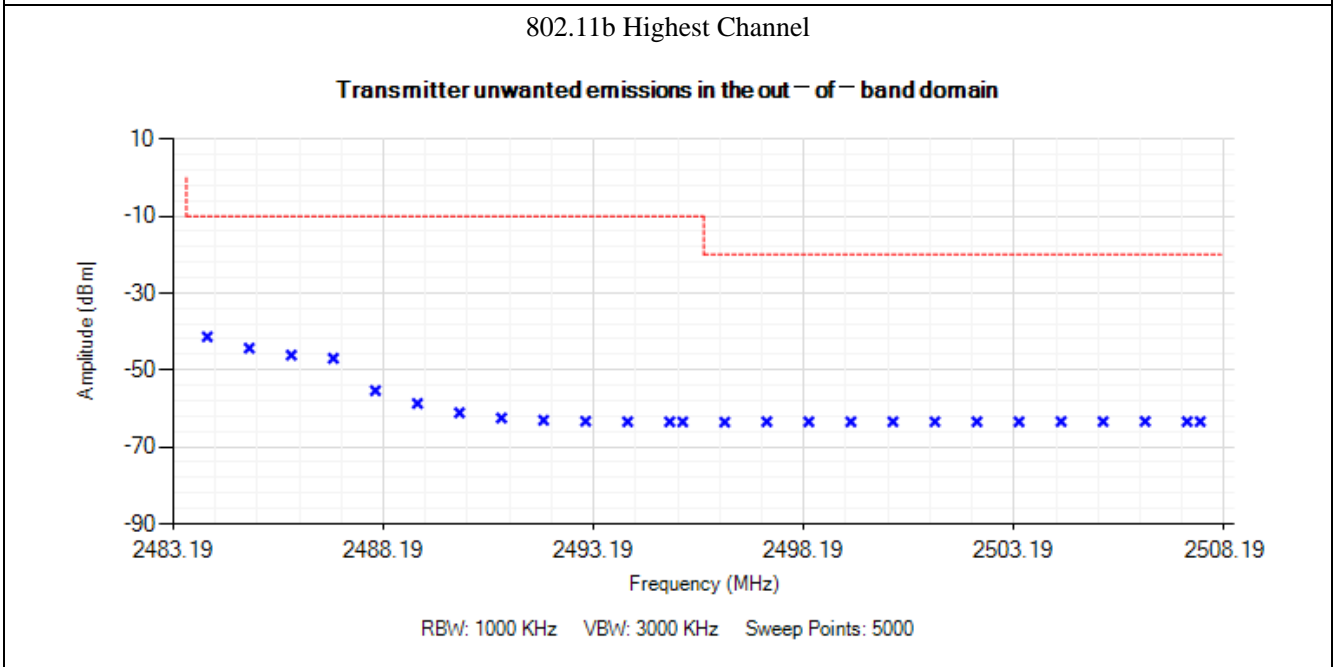
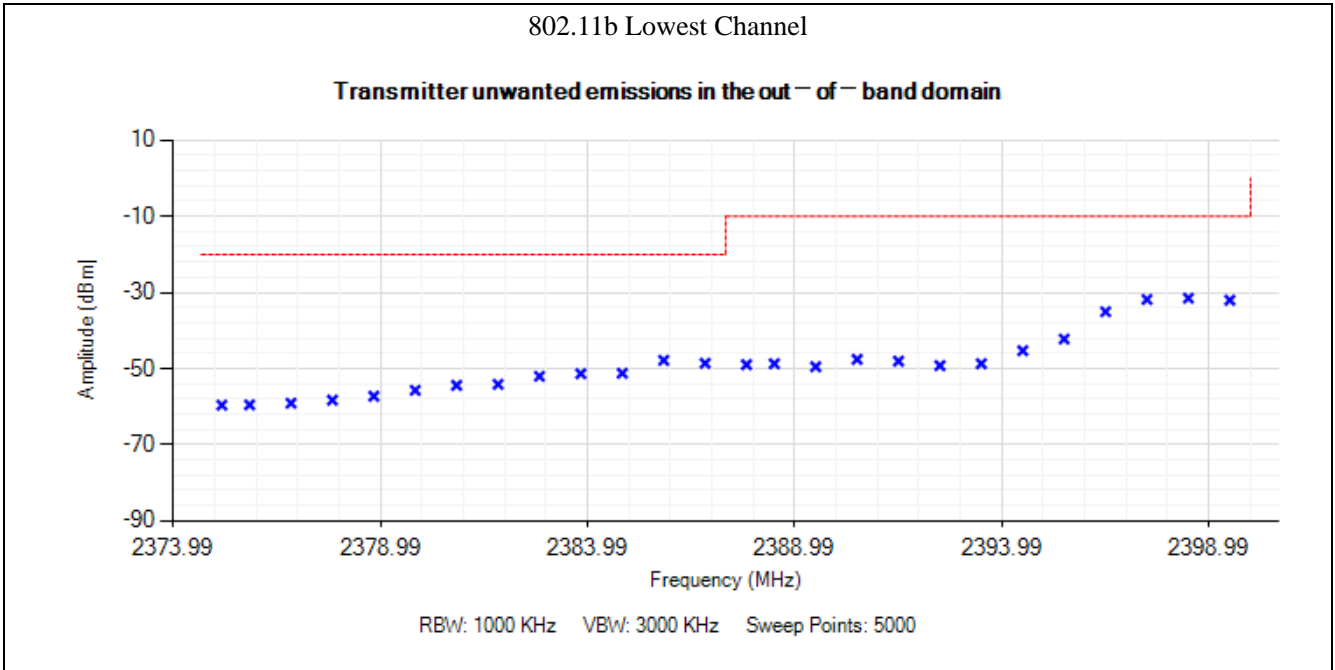

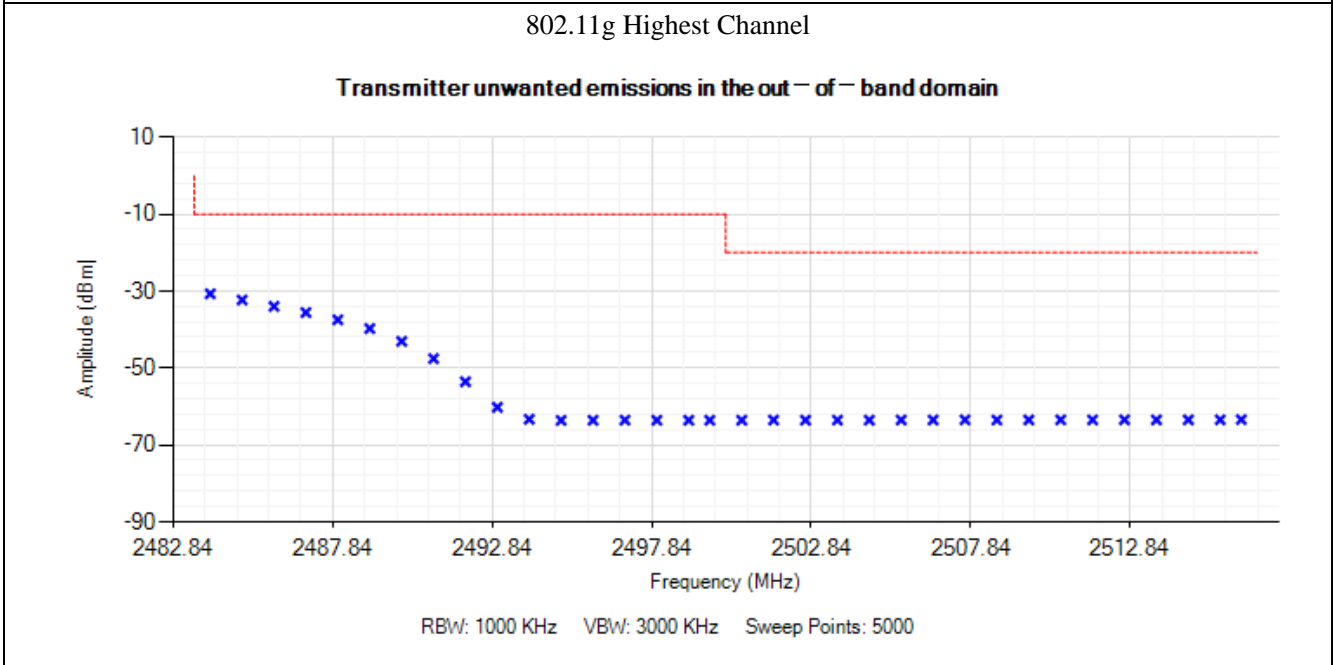
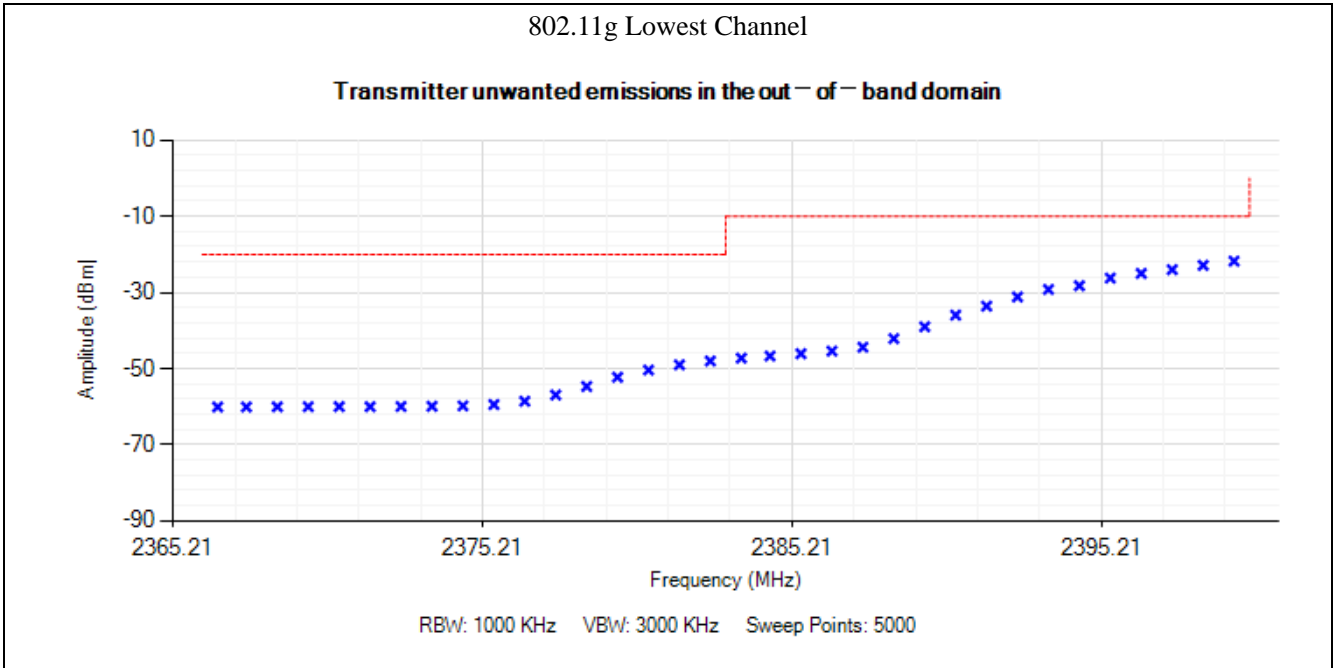

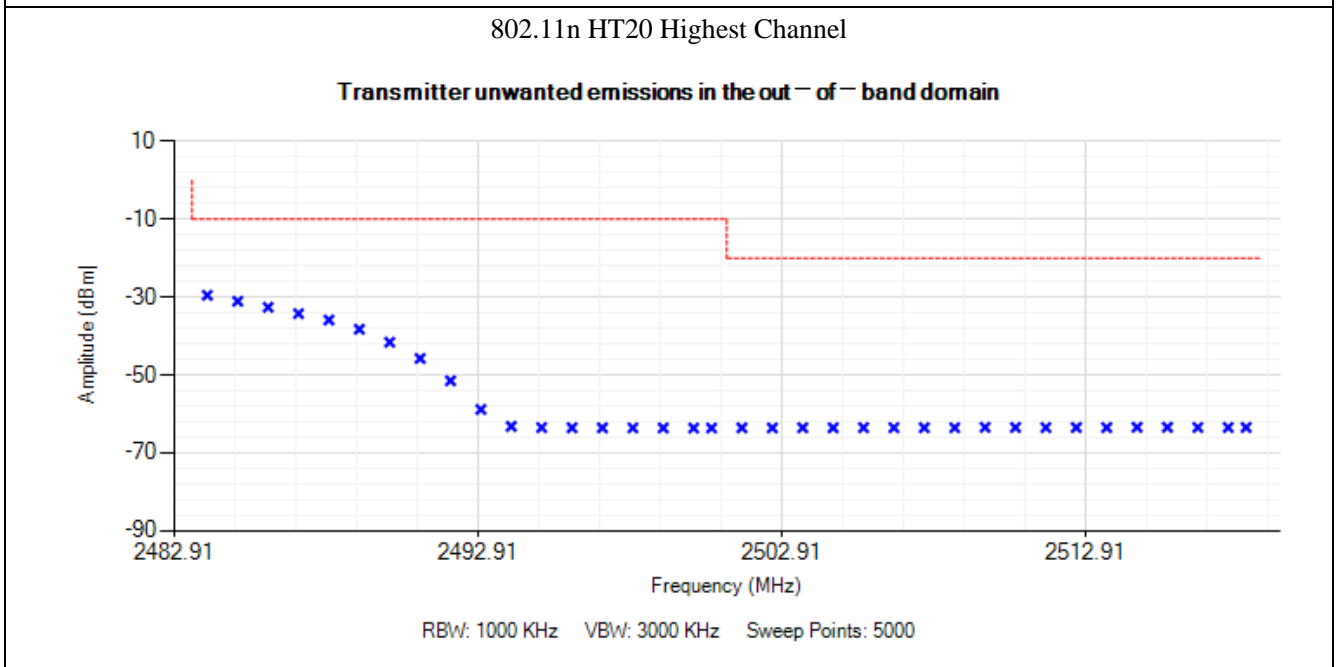
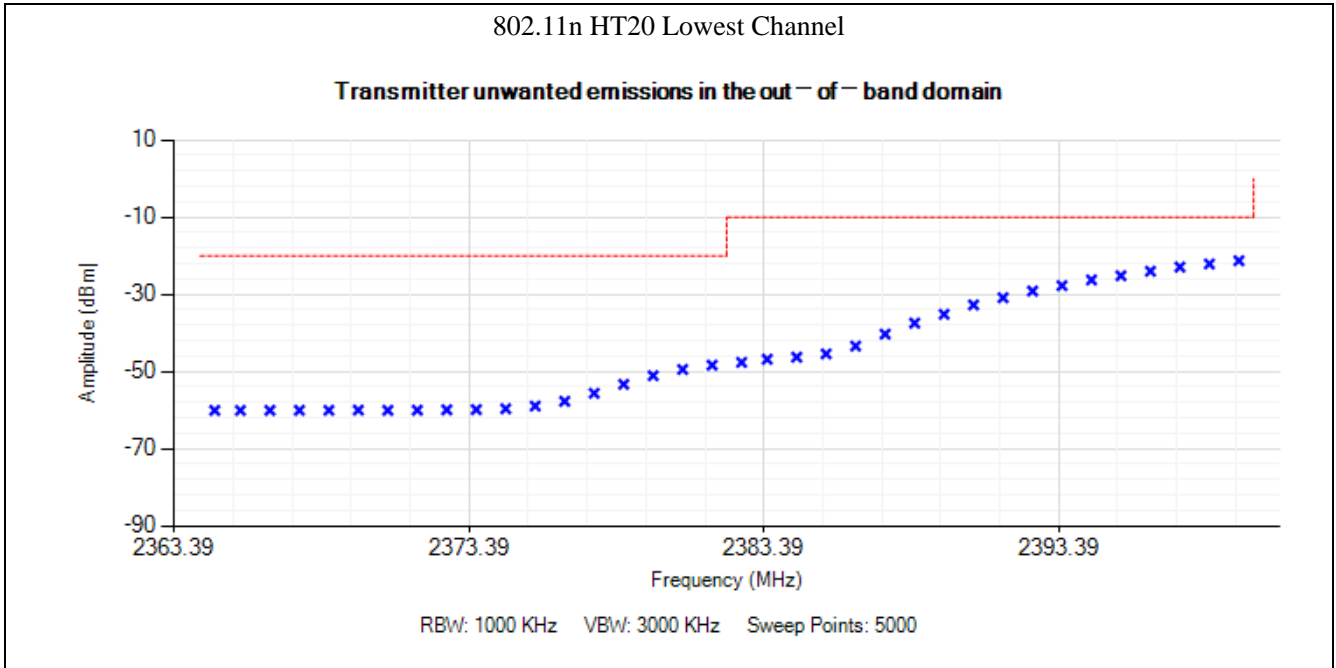

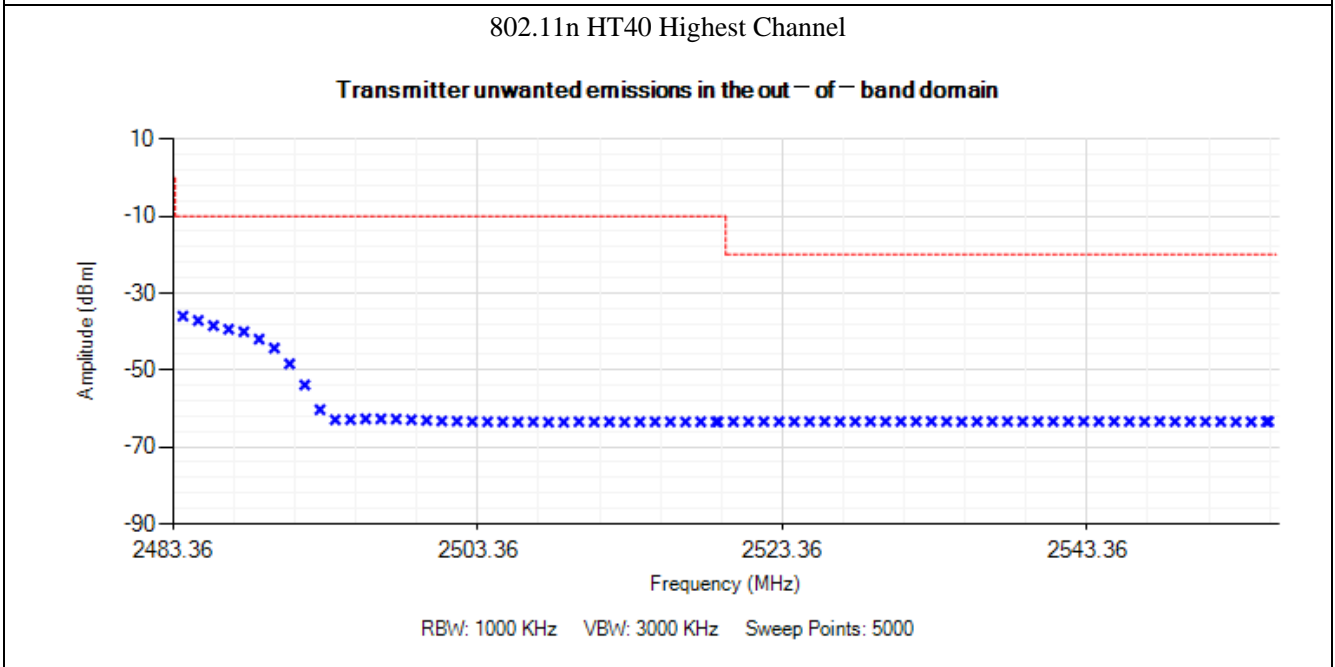
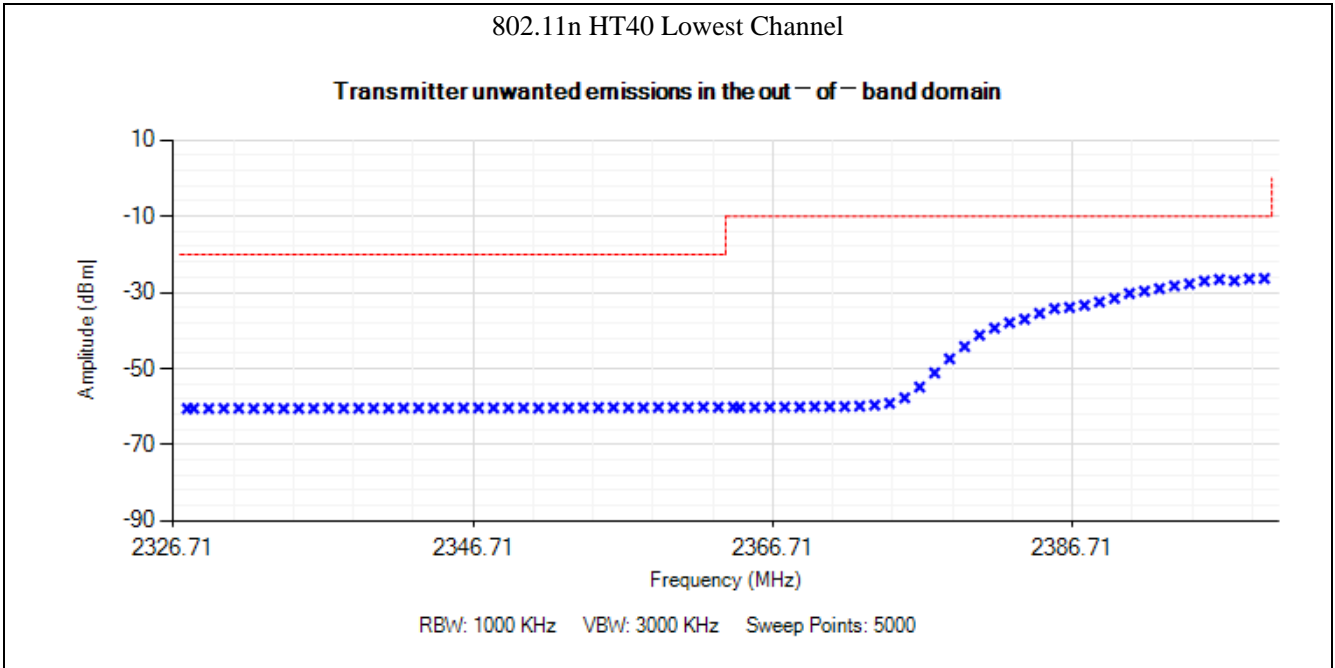

8. Transmitter Unwanted Emissions in the Spurious Domain

8.1 Standard Applicable

According to section 4.3.2.9.3. The transmitter unwanted emissions in the spurious domain shall not exceed the values given in the following table.

Transmitter limit for spurious emissions

Frequency range	Maximum power, e.r.p. (≤ 1 GHz) e.i.r.p. (> 1 GHz)	Bandwidth
30 MHz to 47 MHz	-36 dBm	100 kHz
47 MHz to 74 MHz	-54 dBm	100 kHz
74 MHz to 87,5 MHz	-36 dBm	100 kHz
87,5 MHz to 118 MHz	-54 dBm	100 kHz
118 MHz to 174 MHz	-36 dBm	100 kHz
174 MHz to 230 MHz	-54 dBm	100 kHz
230 MHz to 470 MHz	-36 dBm	100 kHz
470 MHz to 862 MHz	-54 dBm	100 kHz
862 MHz to 1 GHz	-36 dBm	100 kHz
1 GHz to 12,75 GHz	-30 dBm	1 MHz

8.2 Test Procedure

See clause 5.1 for the test conditions. These measurements shall only be performed at normal test conditions.

The level of spurious emissions shall be measured as, either:

- their power in a specified load (conducted spurious emissions) and their effective radiated power when radiated by the cabinet or structure of the equipment (cabinet radiation); or
- their effective radiated power when radiated by cabinet and antenna in case of integral antenna equipment with no temporary antenna connectors

The device under test has an integral antenna and the radiated measurement shall apply to the device, using the method of measurement as described in the EN300328 section 5.3.10.2.

RBW=100kHz VBW=300kHz 30MHz-1GHz

RBW=1MHz VBW=3MHz 1GHz-12.75GHz

8.3 Summary of Test Results/Plots

According to the data, the EUT complied with the EN 300328 standards, and had the worst cases:

Spurious Emission from 30MHz to 1GHz

Lowest channel

Horizontal:

(802.11b-worst case)

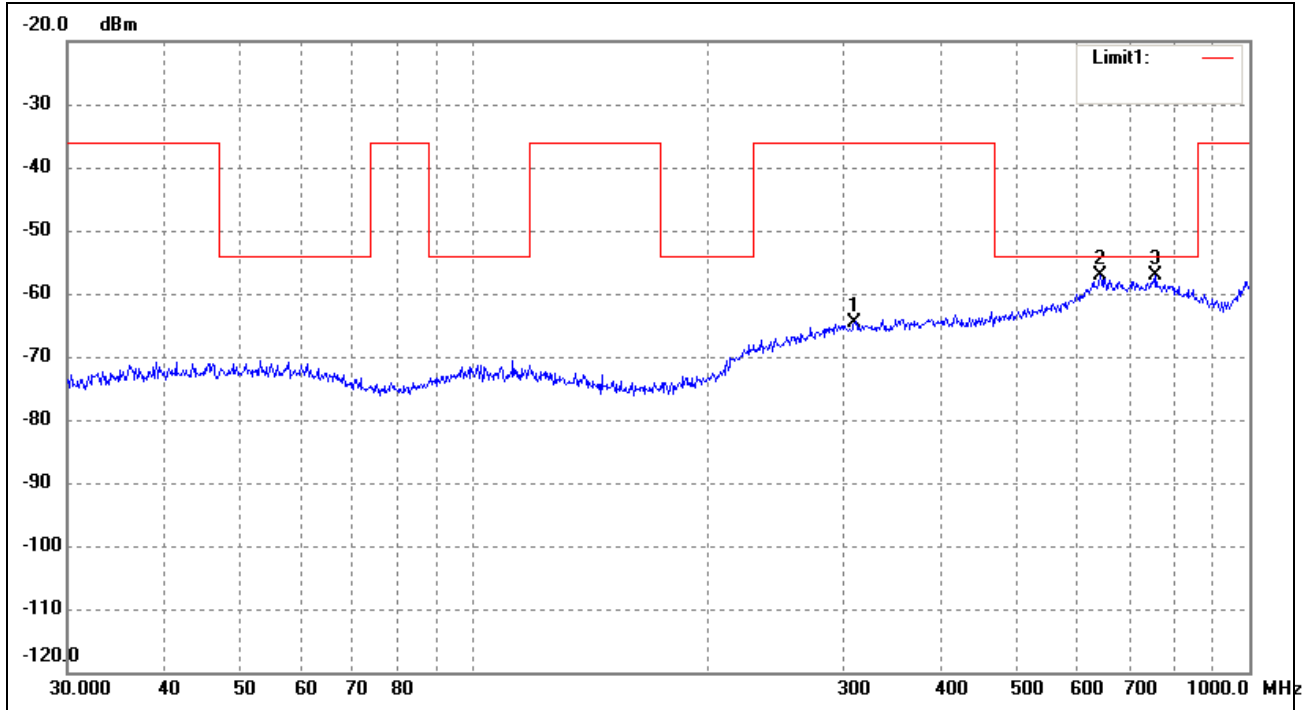

No.	Frequency (MHz)	Reading (dBm)	Correct dB	Result (dBm)	Limit (dBm)	Margin (dB)	Remark
1	309.9977	-88.35	23.75	-64.60	-36.00	-28.60	ERP
2	642.8613	-86.89	29.80	-57.09	-54.00	-3.09	ERP
3	758.0408	-87.23	30.03	-57.20	-54.00	-3.20	ERP

Vertical:

(802.11b-worst case)

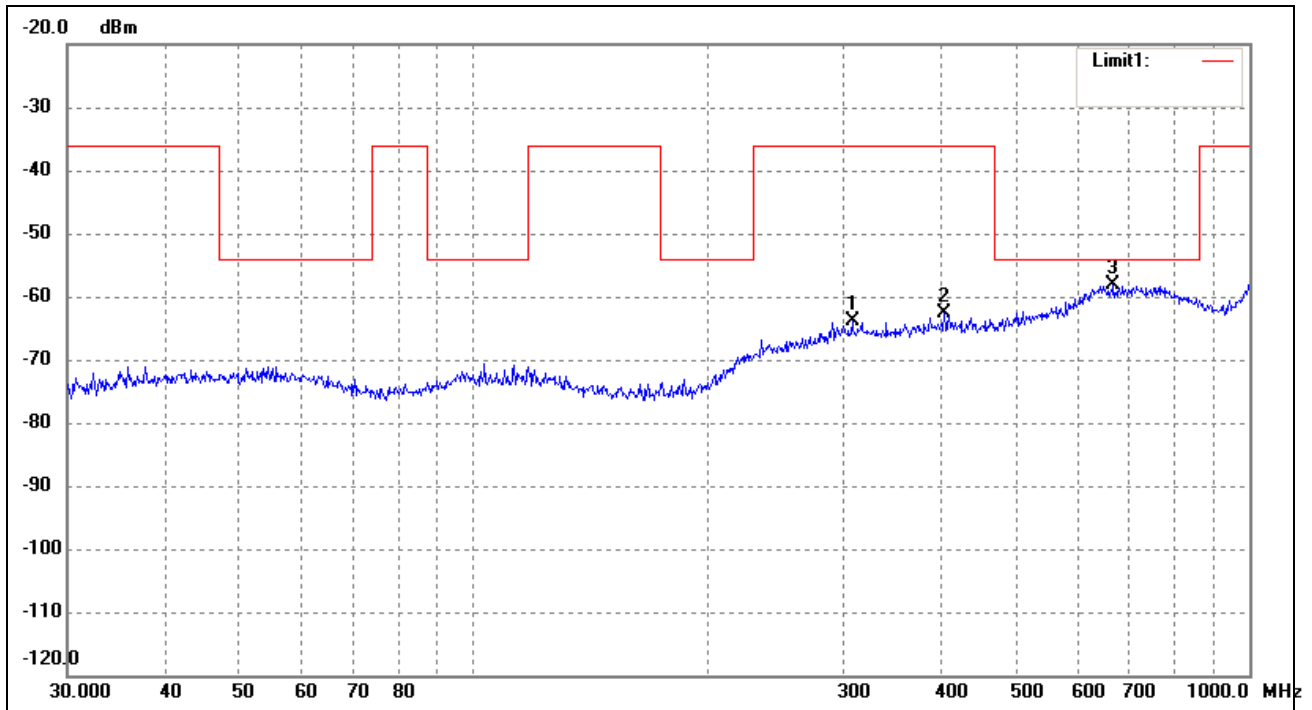

No.	Frequency (MHz)	Reading (dBm)	Correct dB	Result (dBm)	Limit (dBm)	Margin (dB)	Remark
1	307.8313	-87.55	23.74	-63.81	-36.00	-27.81	ERP
2	404.6665	-86.85	24.30	-62.55	-36.00	-26.55	ERP
3	668.1423	-87.98	29.83	-58.15	-54.00	-4.15	ERP

Highest channel

Horizontal:

(802.11b-worst case)

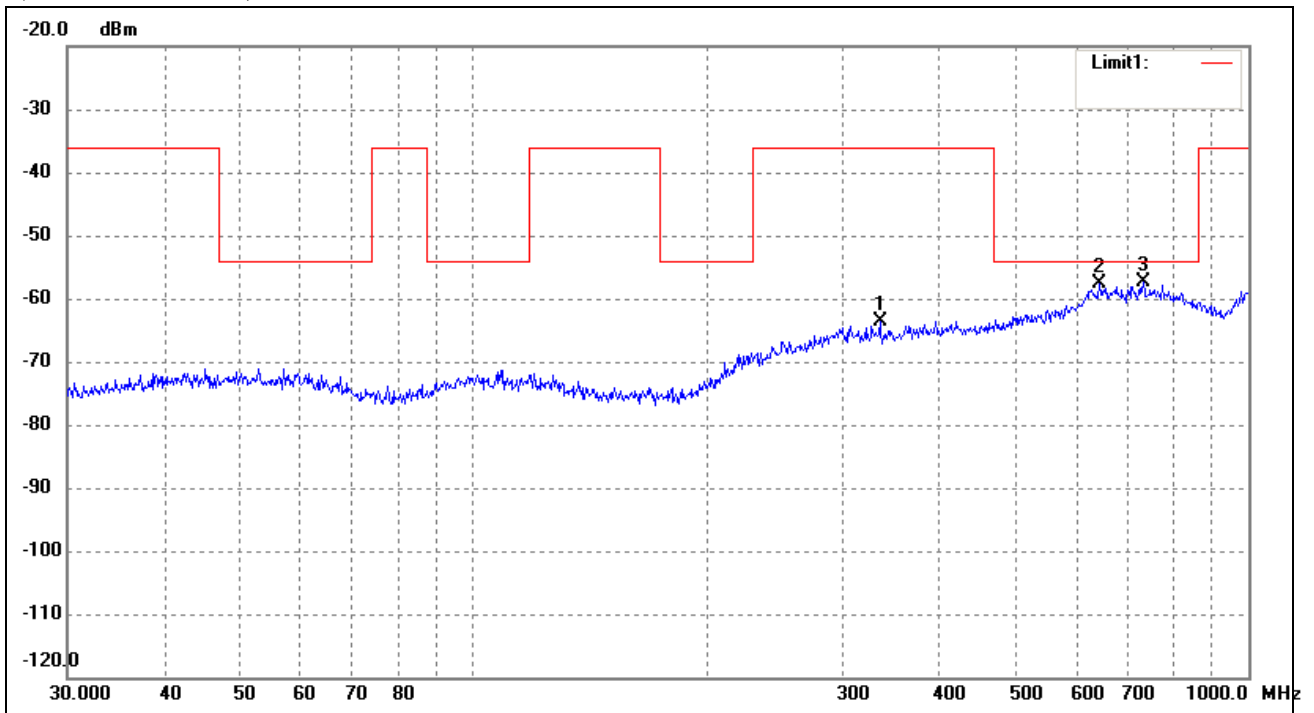

No.	Frequency (MHz)	Reading (dBm)	Correct (dB)	Result (dBm)	Limit (dBm)	Margin (dB)	Remark
1	334.8589	-87.01	23.31	-63.70	-36.00	-27.70	ERP
2	642.8613	-87.39	29.80	-57.59	-54.00	-3.59	ERP
3	731.9203	-87.80	30.34	-57.46	-54.00	-3.46	ERP

Vertical:
(802.11b-worst case)

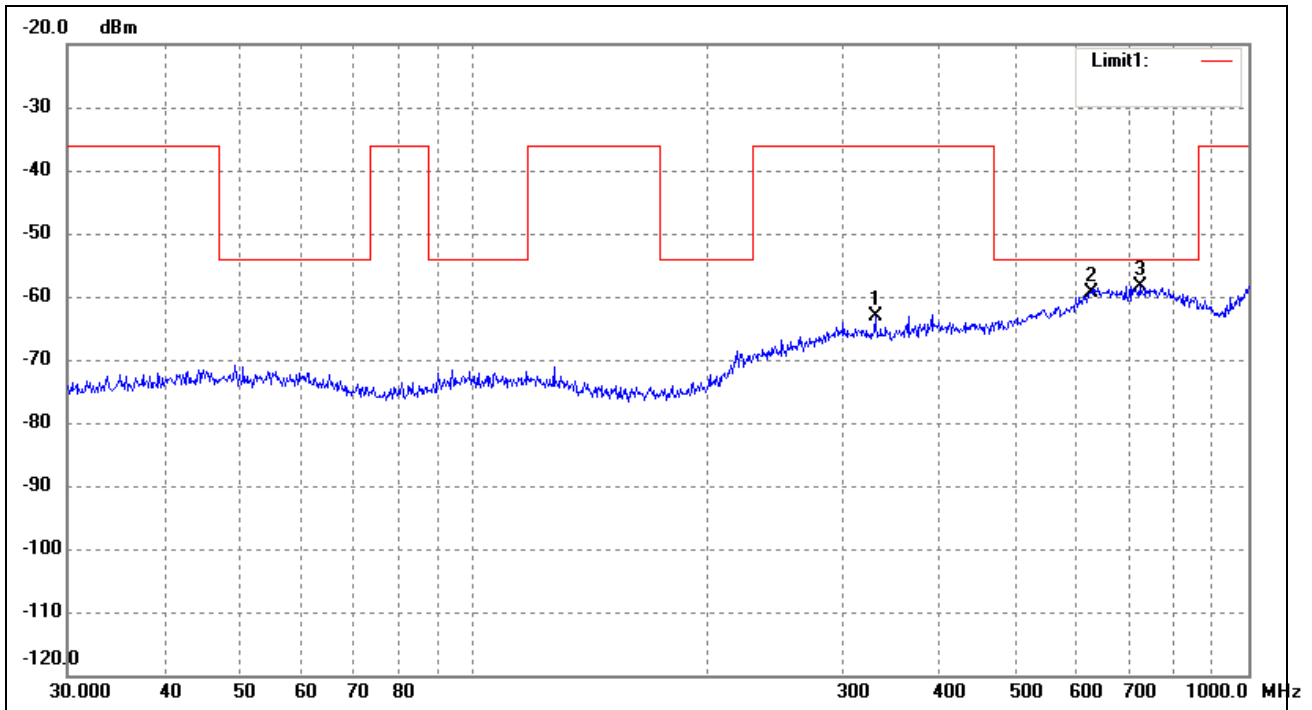

No.	Frequency (MHz)	Reading (dBm)	Correct dB	Result (dBm)	Limit (dBm)	Margin (dB)	Remark
1	330.1949	-86.54	23.44	-63.10	-36.00	-27.10	ERP
2	627.2738	-88.68	29.41	-59.27	-54.00	-5.27	ERP
3	724.2611	-88.15	29.87	-58.28	-54.00	-4.28	ERP

Spurious Emission above 1GHz

Frequency	Reading	Correct	Result	Limit	Margin	Polar
(MHz)	(dBm)	dB	(dBm)	(dBm)	(dB)	H/V
<i>Lowest Channel-2412MHz (802.11b-worst case)</i>						
4824.0	-46.63	7.92	-38.71	-30	-8.71	H
7236.0	-46.89	13.64	-33.25	-30	-3.25	H
4824.0	-49.61	7.92	-41.69	-30	-11.69	V
7236.0	-49.80	13.97	-35.83	-30	-5.83	V
<i>Highest Channel-2472MHz (802.11b-worst case)</i>						
4944.0	-47.86	8.27	-39.59	-30	-9.59	H
7416.0	-49.04	13.73	-35.31	-30	-5.31	H
4944.0	-49.35	8.27	-41.08	-30	-11.08	V
7416.0	-50.83	13.73	-37.10	-30	-7.10	V

Note 1: Testing is carried out with frequency rang 30MHz to 12.75GHz, which above 3th Harmonics are attenuated more than 20dB below the permissible limits or the field strength is too small to be measured.

Note 2: this EUT was tested in 3 orthogonal positions and the worst case position data was reported.

Conducted Transmitter Spurious Emission:

Measurement frequency range(MHz)	Max. spurious emission frequency (MHz)	Measured value dBm	Limit dBm	Result
<i>Low Channel 2412MHz (802.11b-worst case)</i>				
30-47	38.70	-56.52	-36	Pass
47-74	55.65	-64.78	-54	Pass
74-87.5	83.48	-60.87	-36	Pass
87.5-118	91.74	-61.30	-54	Pass
118-174	133.04	-51.74	-36	Pass
174-230	224.78	-62.17	-54	Pass
230-470	233.91	-56.96	-36	Pass
470-862	875.65	-68.26	-54	Pass
862-1000	1413.91	-67.39	-36	Pass
1000-12750	4801.30	-54.78	-30	Pass
<i>High Channel 2472MHz (802.11b-worst case)</i>				
30-47	40.87	-56.09	-36	Pass
47-74	61.74	-66.96	-54	Pass
74-87.5	82.61	-50.00	-36	Pass
87.5-118	112.61	-66.52	-54	Pass
118-174	123.04	-57.83	-36	Pass
174-230	228.70	-65.22	-54	Pass
230-470	306.09	-53.04	-36	Pass
470-862	1034.78	-69.13	-54	Pass
862-1000	1318.26	-52.61	-36	Pass
1000-12750	5509.57	-63.48	-30	Pass

9. Receiver Spurious Emissions

9.1 Standard Applicable

According to section 4.3.2.10.3, The spurious emissions of the receiver shall not exceed the values given in the following table .

Spurious emission limits for receivers

Frequency range	Maximum power e.r.p. (≤ 1 GHz) e.i.r.p. (> 1 GHz)	Measurement bandwidth
30 MHz to 1 GHz	-57 dBm	100 kHz
1 GHz to 12,75 GHz	-47 dBm	1 MHz

9.2 Test Procedure

See clause 5.1 for the test conditions. These measurements shall only be performed at normal test conditions.

The level of spurious emissions shall be measured as, either:

- their power in a specified load (conducted spurious emissions) and their effective radiated power when radiated by the cabinet or structure of the equipment (cabinet radiation); or
- their effective radiated power when radiated by cabinet and antenna in case of integral antenna equipment with no temporary antenna connectors

The device under test has an integral antenna and the radiated measurement shall apply to the device, using the method of measurement as described in the EN300328 section 5.3.11.2.

RBW=100kHz VBW=300kHz 30MHz-1GHz

RBW=1MHz VBW=3MHz 1GHz-12.75GHz

9.3 Summary of Test Results/Plots

According to the data, the EUT complied with the EN 300328 standards, and had the worst cases:

Test Mode: Receiving

Horizontal:

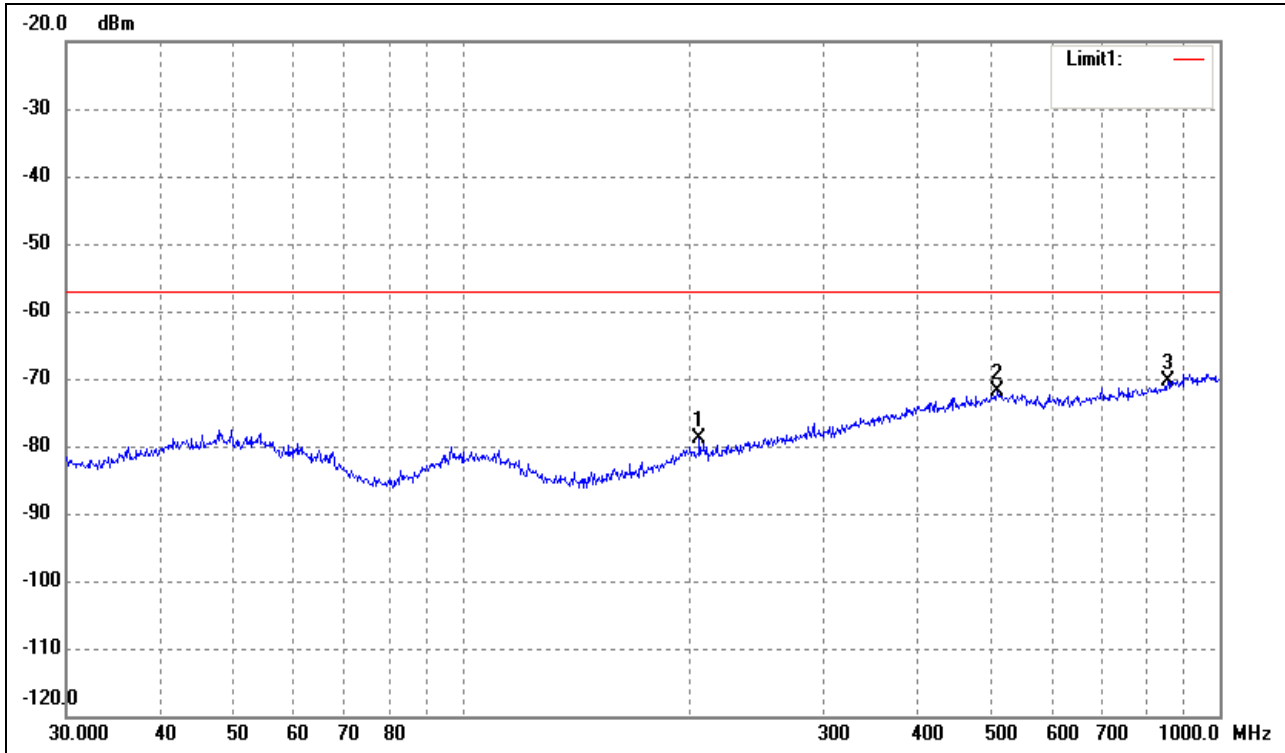

No.	Frequency (MHz)	Reading (dBm)	Correct (dB)	Result (dBm)	Limit (dBm)	Margin (dB)	Remark
1	205.6751	-81.60	2.79	-78.81	-57.00	-21.81	ERP
2	508.2582	-82.60	10.63	-71.97	-57.00	-14.97	ERP
3*	854.0247	-82.83	12.47	-70.36	-57.00	-13.36	ERP

Vertical

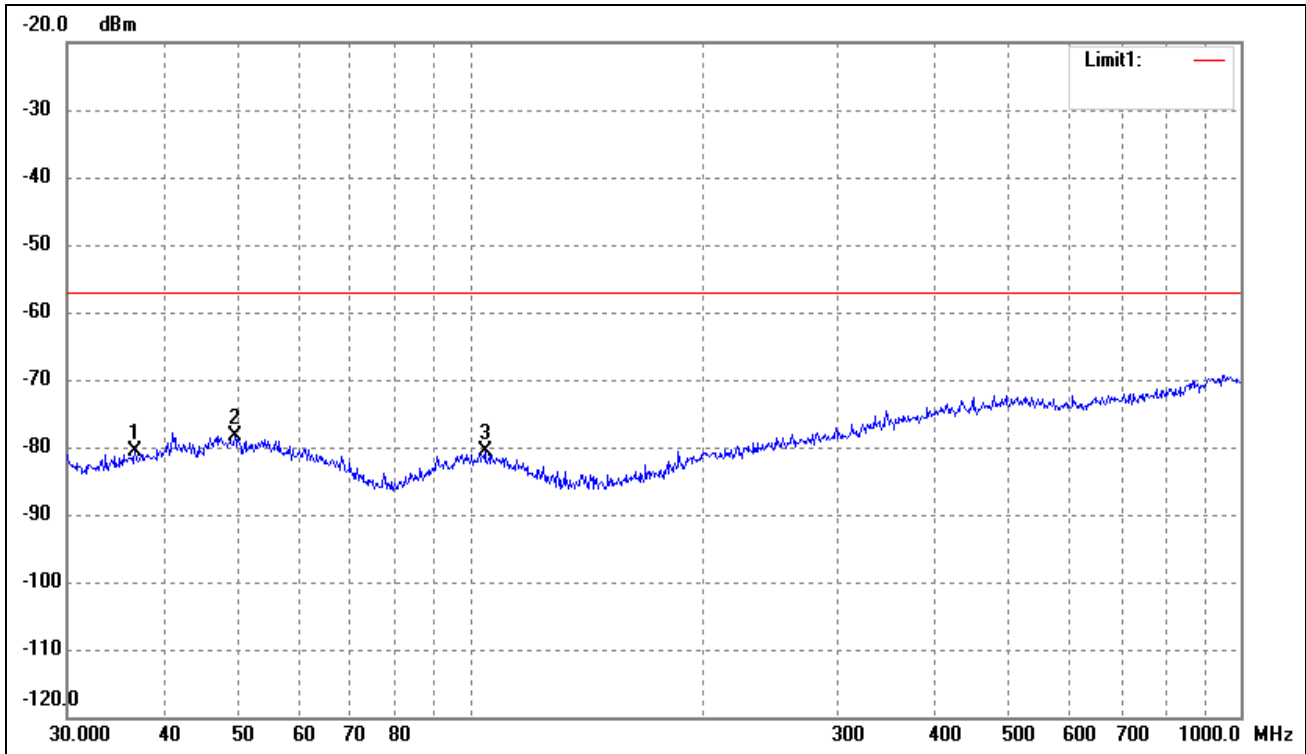

No.	Frequency (MHz)	Reading (dBm)	Correct dB	Result (dBm)	Limit (dBm)	Margin (dB)	Remark
1	36.7662	-71.39	-9.33	-80.72	-57.00	-23.72	ERP
2*	49.5328	-71.03	-7.45	-78.48	-57.00	-21.48	ERP
3	104.5361	-71.07	-9.58	-80.65	-57.00	-23.65	ERP

Note: Testing is carried out with frequency rang 30MHz to 12.75GHz, which above 1GHz are attenuated more than 20dB below the permissible limits or the field strength is too small to be measured.

Conducted Receiver Spurious Emission:

Worst Case 802.11b

Measurement frequency range(MHz)	Max. spurious emission frequency (MHz)	Measured value dBm	Limit dBm	Result
30-1000	639.13	-67.67	-57	Pass
1000-12750	1825.65	-63.43	-47	Pass

EXHIBIT 1 - PRODUCT LABELING

Proposed CE Label Format

Smart Phone
Model: VOLT X
Input: 5V[⎓], 1A or Powered by 3.8V, 4000mAh
Rechargeable Li-polymer Battery
CE 0700 
Gui zhou Fortuneship Technology Co., Ltd.

Specifications: Text is Black in color and is justified. Labels are printed in indelible ink on permanent adhesive backing or silk-screened onto the EUT or shall be affixed to a conspicuous location on the EUT. The ‘CE’ marking must be affixed to the EUT or to its data plate. Where this is not possible or not warranted on account of the nature of the apparatus, it must be affixed to the packaging, if any, and to the accompanying documents. The ‘CE’ marking is allowed less than 5 mm but must clear. If the ‘CE’ marking is reduced or enlarged the proportions given in the above graduated drawing must be respected. The Importer name, address and Manufacturer name and address should indicate on marking label or packaging or in a document accompanying

Proposed Label Location on EUT

CE Label Location



EXHIBIT 2 - EUT PHOTOGRAPHS

EUT View 1



EUT View 2



EUT View 3**EUT Housing and Board View 1**

EUT Housing and Board View 2



EUT Housing and Board View 3



EUT Housing and Board View 4



Solder Board-Component View 1

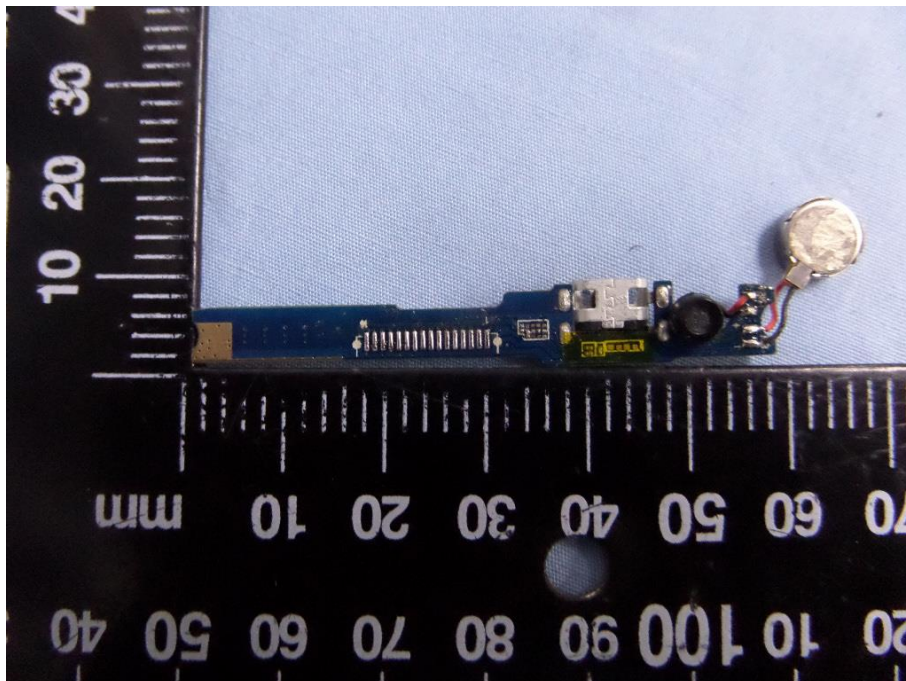

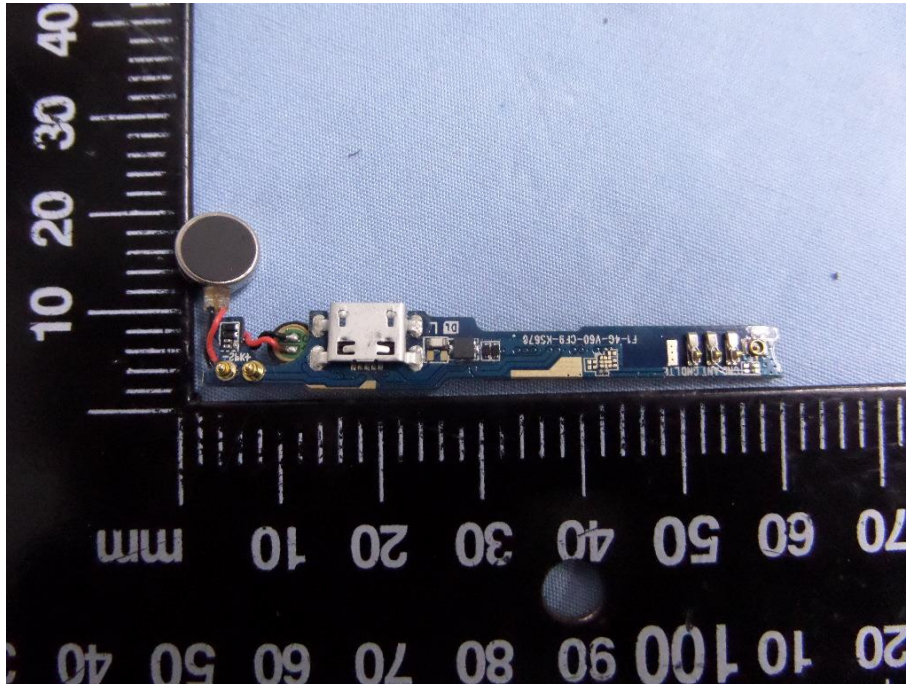
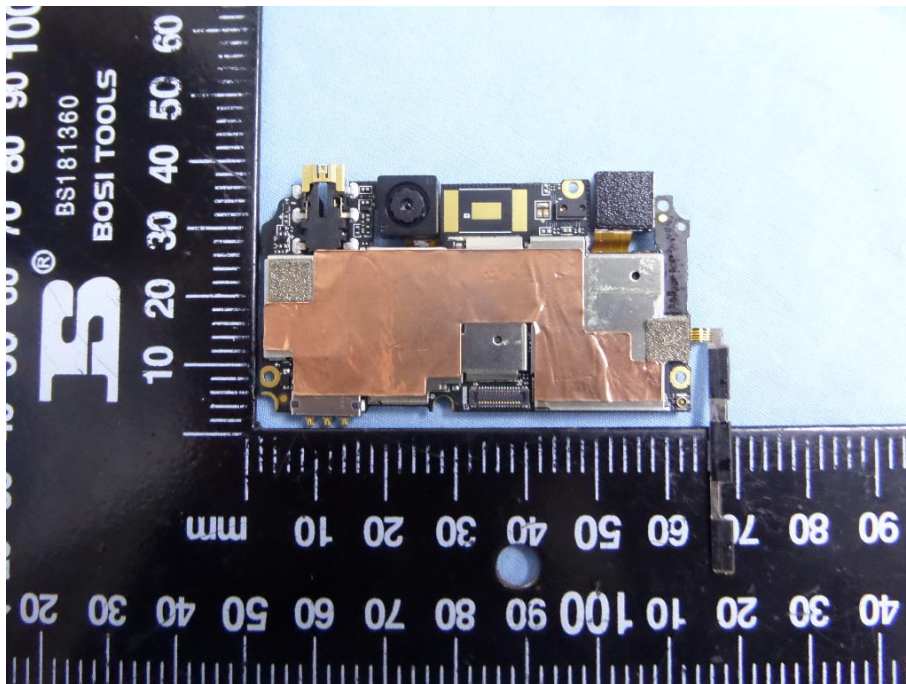
Solder Board-Component View 2**Solder Board-Component View 3**

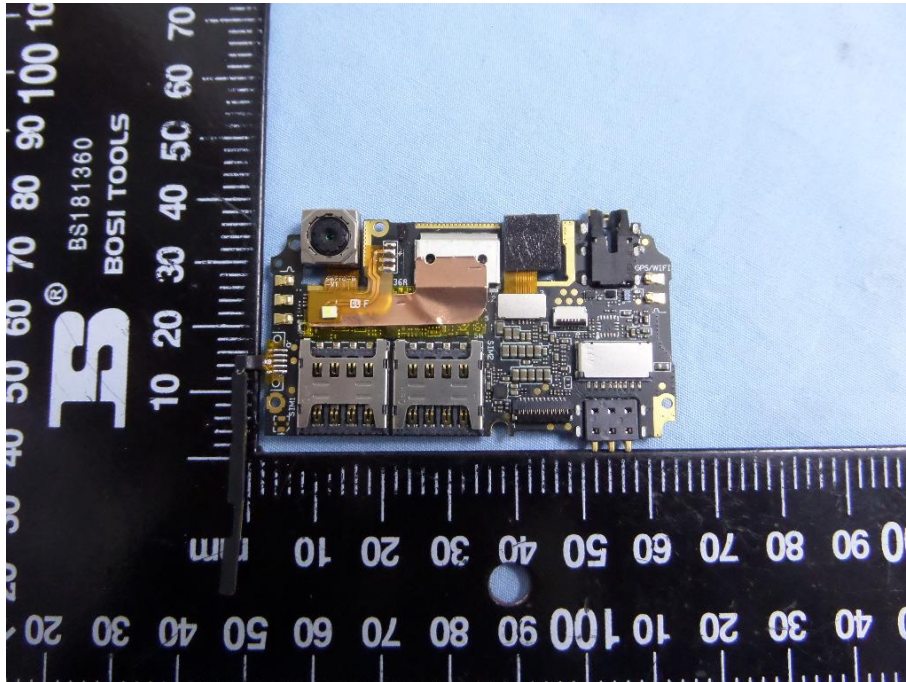
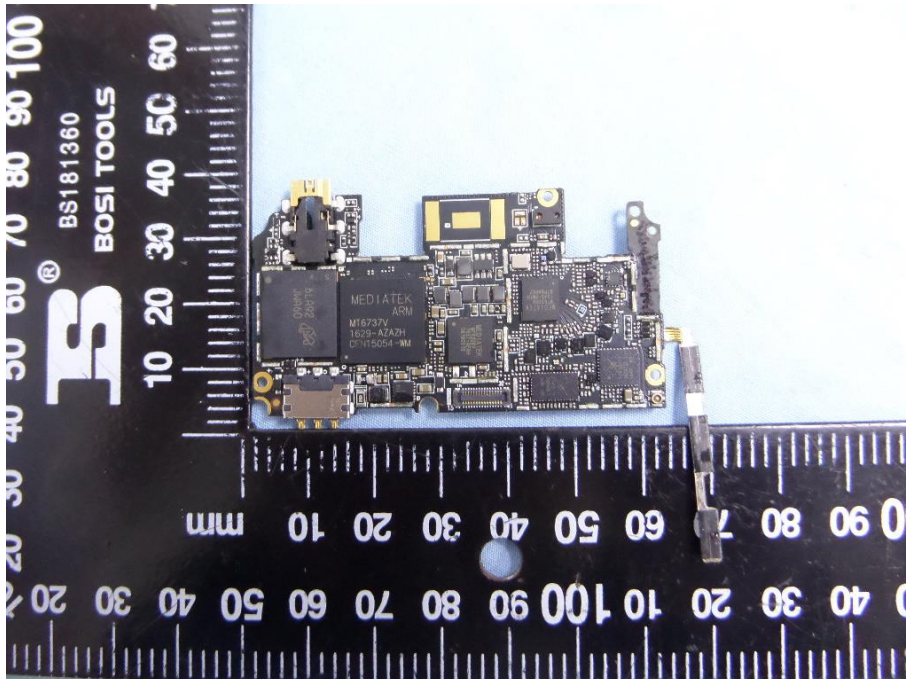
Solder Board-Component View 4**Solder Board-Component View 5**

Solder Board-Component View 6

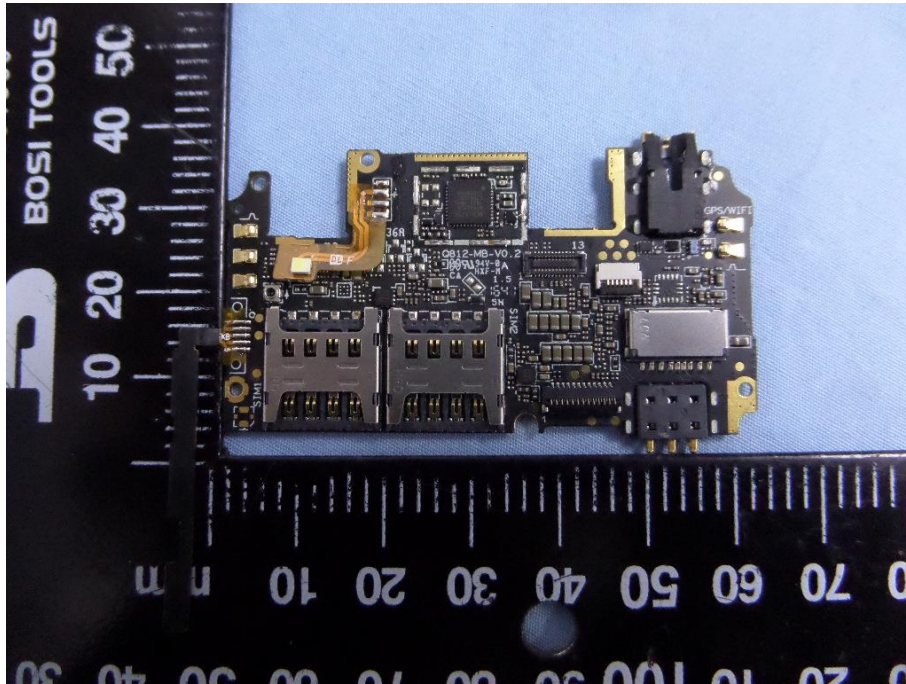

Antenna View

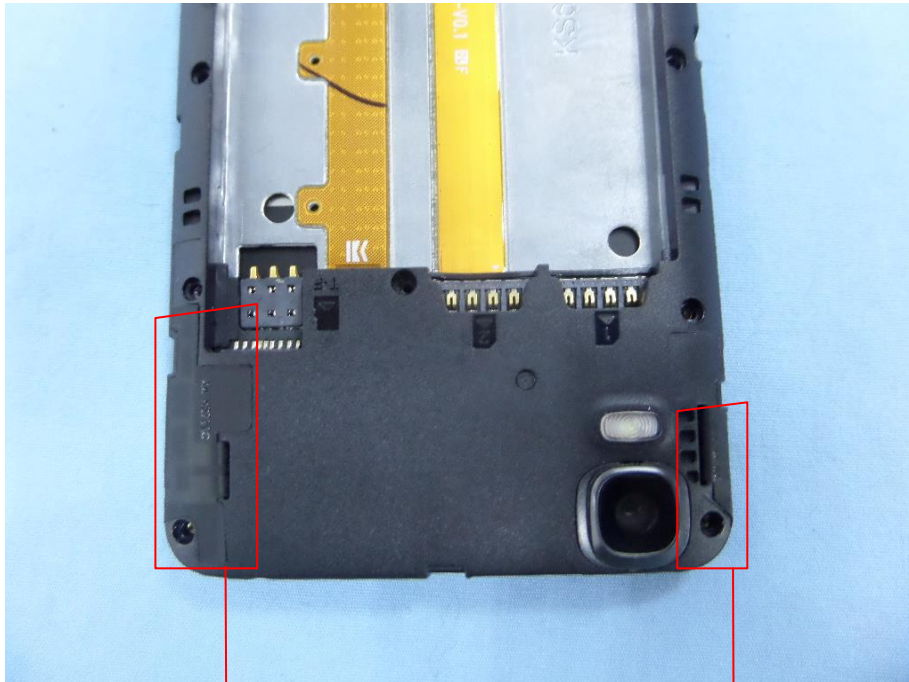

Wi-Fi/BT/GPS Ant.

LTE_Rx Ant.



GSM/WCDMA/LTE Ant.

EXHIBIT 3 - TEST SETUP PHOTOGRAPHS

Spurious Emission Test Setup (Below 1GHz)



Spurious Emission Test Setup (Above 1GHz)



Extreme Condition Test Setup

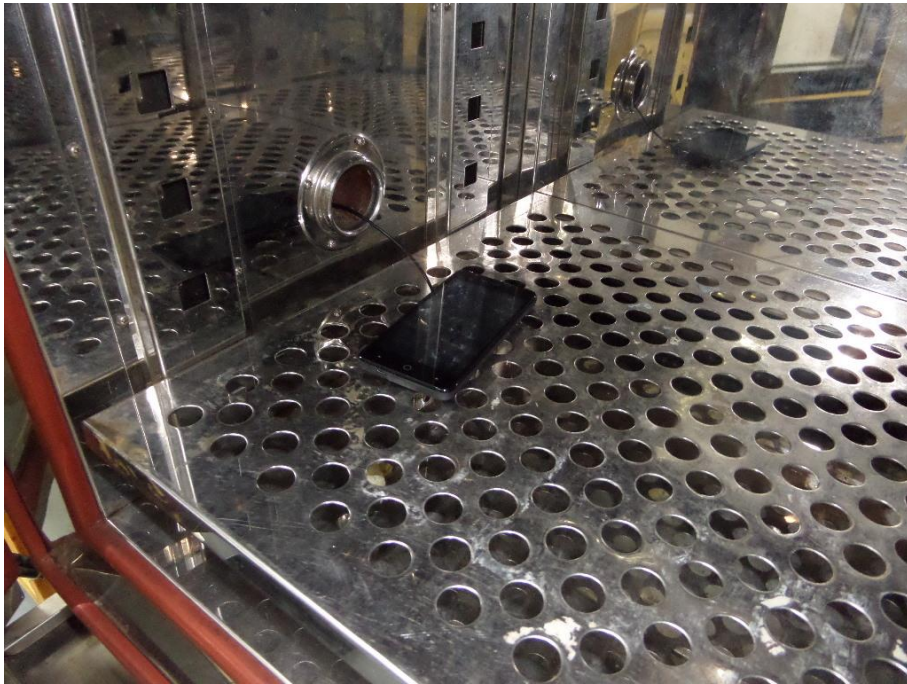

***** END OF REPORT *****